



MAINTENANCE GUIDE

for

Captor™ 4300, 4800 (Battery) CR 1100, 1200 (Battery)



AFTER USE

- 1 Raise the squeegee, the scrub brushes, and the brooms.
- 2 Shake the dust control filter and empty the hopper.
- 3 Drain and flush the recovery tank.
- 4 Tip the recovery tank out and check the squeegee hose elbow below the tank for debris. DO NOT run water down the recovery tank vacuum tubes, this may cause damage to the vacuum motors.
- 5 Remove and clean the squeegee tool.
- 6 Remove and clean the scrub brushes. Rotate the scrub brushes.
- 7 Wipe the machine with a damp cloth.
- 8 Perform all required maintenance before storage.
- 9 Move the machine to a clean, dry storage area.
- 10 Store the machine with the brooms, the squeegee and the scrub brushes in the UP position, and the tank covers open so that the tanks can air out.

REPORT ANY DEFECT OR MALFUNCTION NOTED DURING OPERATION TO AUTHORIZED SERVICE OR MAINTENANCE PERSONNEL.

CHARGING THE BATTERY

Charge the battery each time the machine is used, or whenever the Battery Condition Meter Lights (DD) are flashing.

To Charge the Battery...

- 1 Open the Battery Compartment Door (21) to provide proper ventilation.
- 2 Disconnect the battery from the machine (KK) and connect the charger plug to the battery plug.
- 3 Follow the instructions on the battery charger.
- 4 Check the fluid level in all battery cells after charging the battery. Add distilled water, if necessary, to bring the fluid level up to the bottom of the filler tubes.

WARNING!

Do not fill the battery before charging.
Only charge battery in a well-ventilated area.
Do not smoke while servicing the battery.

CAUTION!

To avoid damage to floor surfaces, always wipe water and acid from the top of the battery after charging.

CHECKING THE BATTERY ELECTROLYTE LEVEL

Check the electrolyte level of the battery at least once a week. After charging the battery, remove the vent caps and check the electrolyte level in each battery cell. Use distilled water to fill the battery to the bottom of the filler tube.

Do not over-fill the battery!

CAUTION!

Acid can spill onto the floor if the battery is overfilled.
Tighten the vent caps. If there is acid on the battery, wash the top of the battery with a solution of baking soda and water (2 tablespoons of baking soda to 1 quart of water).

MAIN BROOM MAINTENANCE

Since the Main Broom Motor always turns in the same direction, the bristles on the broom eventually become curved, reducing sweeping performance. Sweeping performance can be improved by removing the broom and turning it around (end-for-end). This procedure, known as "rotating" the main broom, should be done once every 25 hours of operation.

The main broom should be replaced when the bristles are worn to a length of 2-1/2 inches (6.35 cm). The main broom stop (GG) must be re-adjusted when the broom is replaced. NOTE: Bristle length on a new broom is 3-1/4 inches (8.25cm).

NOTE: The machine should be stored with the Main Broom in the raised position.

WARNING!

Disconnect the battery (KK) before performing this operation.

To Rotate or Replace the Main Broom...

- 1 Turn the Main Power Switch (CC) OFF.
- 2 Put the Main Broom Raise / Lower (ON/OFF) Lever (FF) in the DOWN position.
- 3 Open the Main Broom Right Access Door (29).
- 4 See Figure 1. Remove the large T-Bolt (A1) from the side of the broom idler arm. Pivot the idler arm assembly out of the main broom core.
- 5 Pull the main broom out of the broom housing and remove any string or wire wrapped around it. Also inspect the skirts at the front, back and sides of the broom housing. The skirts should be replaced or adjusted if they are torn or worn to a height of more than 1/4 inch (6.35 mm) off the ground.
- 6 Turn the broom around (end-for-end) and slide it back into the broom housing. Make sure that the Lugs (B1) on the broom drive hub (left side of machine) engage the slots in the broom core.
- 7 Swing the idler arm assembly back into the broom core and re-install the T-Bolt that holds the idler arm in place.
- 8 Close and latch the Main Broom Right Access Door (29).

To Adjust the Main Broom Height...

- 1 Drive the machine to an area with a level floor and set the parking brake (OO).
- 2 Pull the Main Broom Raise / Lower (ON/OFF) Lever (FF) back and slide to the right and up to lower the main broom. Push lightly on the front of the Drive Pedal (MM) to start the main broom rotating. DO NOT move the machine.
- 3 Let the main broom run in place for 1 minute. This allows the broom to polish a "strip" on the floor. After 1 minute, raise the broom, release the parking brake and move the machine so that the polished strip is visible.
- 4 Inspect the polished strip on the floor. If the strip is less than 2 inches (5.08 cm) or more than 3 inches (7.62cm) wide, the broom needs to be adjusted.
- 5 To adjust, loosen the Main Broom Adjust Knob (GG) and slide forward or backward to lower or raise the Main Broom. The farther the Knob (GG) travels up in the slot, the lower the Main Broom will be. Tighten Knob (GG) after adjustment is complete.
- 6 Repeat steps 1-5 until the polished strip is 2-3 inches (5.08-7.62cm) wide. The width of the polished strip should be the same at both ends of the broom. If the strip is tapered, move the machine to a different area and repeat steps 1-5. If the polished strip is still tapered, contact your Nilfisk-Advance Dealer for service.

LUBRICATION

Grease Fitting Locations:

- 1 on each steering sprocket, 6 total.
- 2 on drive wheel gear case spindle
- 1 on each squeegee caster, 2 total

Lube Oil Locations:

- steering chain.

MAINTENANCE SCHEDULE

Keep the machine in top condition by following the maintenance schedule closely. Maintenance intervals given are for average operating conditions. Machines used in severe environments may require service more often.

MAINTENANCE ITEM	Daily	25 Hours	150 Hours	300 Hours	Yearly (1,000hrs)
Charge Battery	X				
Drain / Check / Clean Tanks & Hoses	X				
Check / Clean / Rotate Scrub Brushes & Pads	X				
Check / Clean / Adjust Squeegee	X				
*Check / Clean Vacuum Motor Inlet Screen Cap	X				
Clean Solution Filter (32)	X				
Check Battery Cell Water Level(s)		X			
Check Foot/ Parking Brake For Wear & Adjustment		X			
Inspect Broom Housing Skirts		X			
Check Hydraulic Fluid Level		X			
Check / Clean Hopper Dust Control Filter Using Method "A"		X			
Inspect Scrub Deck Skirts		X			
Main Broom Maintenance		X			
Side Broom Maintenance		X			
Lubrication			X		
Inspect Main Broom Upper & Lower Belts			X		
Check / Clean Hopper Dust Control Filter Using Method "B"			X		
Check / Clean Hopper Dust Control Filter Using Method "C"				X	
Replace Hydraulic Oil & Filter					X
** Check Carbon Brushes					X
Have Nilfisk-Advance service center inspect the wheel drive gearbox					X

* DO NOT run water down the vacuum tube in the recovery tank this will damage the vacuum motors. Vacuum tube is on left side of tank with screen cap.

** Have your Nilfisk-Advance Dealer check the carbon motor brushes once a year or after 300 operating hours.

NOTE: Refer to the Service Manual for more detail on maintenance and service repairs.

SIDE BROOM MAINTENANCE

The side broom(s) move dirt and debris away from walls or curbs and into the path of the main broom. Adjust the side broom so that the bristles are contacting the floor from the 10 O'clock (A2) to the 3 O'clock (B2) area shown in Figure 2 when the broom is down and running.

To adjust the Side Broom...

- 1 The side broom(s) are adjusted simply by pressing and holding the Side Broom DOWN/ON Switch (P) or the Side Broom UP/OFF Switch (U) until the desired amount of bristles are contacting the floor.

NOTE: The machine should be stored with the Side Broom(s) in the raised position. The Side Broom(s) should be replaced when the bristles are worn to a length of 3 inches (7.62 cm) or they become ineffective.

To replace the Side Broom...

- 1 Raise the Side Broom(s).
- 2 Reach under the Side Broom and remove the large Thumb-Nut holding the side broom on and remove the broom.
- 3 Install the new broom by aligning the three alignment pins and pushing on. Re-install the Thumb-Nut and tighten.

Figure 2

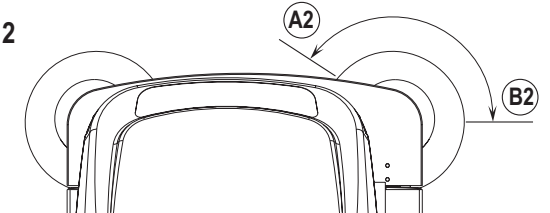

SQUEEGEE MAINTENANCE

After each use, clean the squeegee tool and check the blades for damage. If the squeegee leaves water in the middle of its path or at both ends of its path, it probably needs to be adjusted. Reverse or replace the blades if they are cut, torn, wavy or worn.

To adjust the squeegee:

- 1 Park the machine on a level floor, lower the squeegee and drive forward a short distance.
- 2 See Figure 3. Loosen the two Squeegee Adjustment Lock Nuts (A3).
- 3 Turn the two Squeegee Adjustment Bolts (B3) counter-clockwise for forward tilt or clockwise for backward tilt. Pull forward a short distance after each adjustment to see if the squeegee blades touch the floor evenly across the entire width of the squeegee tool. Then re-tighten the two Nuts (A3). NOTE: Hold Bolts (B3) with wrench while tightening Lock Nuts (A3). NOTE: If adjusting for more forward tilt, tightening the Locknuts (A3) after loosening the Adjustment Bolts (B3) is what will actually tilt the squeegee assembly.

Figure 3

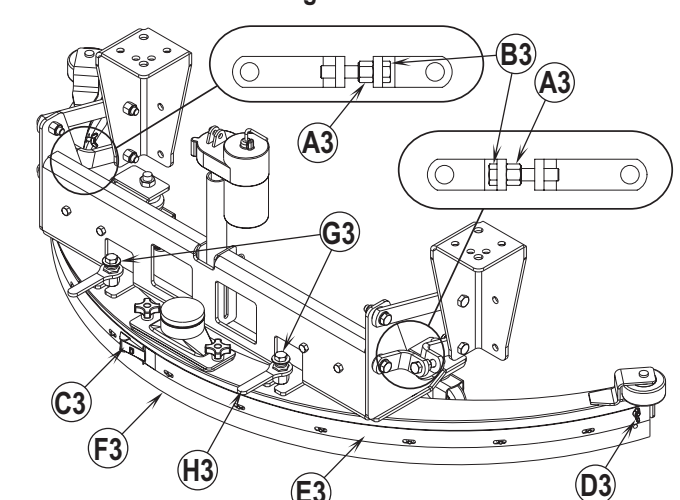

To reverse or replace the rear squeegee blade:

- 1 Unlatch the Rear Squeegee Blade Latch (C3) and remove the (2) Wing Nuts (D3).
- 2 Remove both Rear Straps (E3) and the Rear Squeegee Blade (F3) from the machine.
- 3 The squeegee blade has 4 working edges. Turn the blade so a clean, undamaged edge points toward the front of the machine. Replace the blade if all 4 edges are nicked, torn or worn to a large radius.
- 4 Install the blade, following the steps in reverse order and adjust the squeegee tilt.

To reverse or replace the front squeegee blade:

- 1 Disconnect the Squeegee Hose from the squeegee tool.
- 2 Loosen the (2) Squeegee Levers (G3) and slide the squeegee assembly

off of the squeegee mount.

SERVICE NOTE: Depending on the position of the Squeegee Lever Handle (H3), you may not be able to rotate the lever far enough to loosen or tighten depending on which you are trying to do. In this case, simply lift UP on the Handle (H3) and rotate the lever in the direction necessary to acquire adequate turning space and then allow the lever to drop back DOWN into place on the hex. You can then either tighten or loosen as needed.

- 3 Remove all of the Wing Nuts from the front squeegee blade strap.
- 4 Remove the strap and blade from the squeegee assembly.
- 5 The squeegee blade has 4 working edges. Turn the blade so a clean, undamaged edge points toward the front of the machine. Replace the blade if all 4 edges are nicked, torn or worn to a large radius.
- 6 Install the blade, following the steps in reverse order and adjust the squeegee tilt.

TOWING OR PUSHING A DISABLED MACHINE

CAUTION!

If the machine must be towed or pushed, make sure the Main Power Switch (CC) is in the OFF position and do not move the machine faster than a normal walking pace (2-3 miles per hour) and for short distances only. If the machine is to be moved long distances the rear drive wheel needs to be raised off the floor and placed on a suitable transport dolly.

TROUBLESHOOTING GUIDE

If water flows around the ends of the squeegee tool, instead of being pulled into the tool, the vacuum system is not working properly. When a vacuum system performs poorly, it is usually because of one of the following problems:

Vacuum Leak(s) – Air flowing into the vacuum system past a bad gasket or leaky hose, damaged tank, or a leaky drain valve. A vacuum leak below the water line will create turbulence in the recovery tank, causing water to enter the vacuum motor.

Restriction(s) – Anything that blocks the flow of air through the system. Restrictions may also be caused by built-up debris in the squeegee tool, vacuum hoses, vacuum motor screen or wherever the airflow is forced to make a sharp turn.

Both leaks and restrictions decrease the quantity of air flowing through the squeegee tool. The air that does go through the squeegee tool moves slower, so it has less pick-up power.

VACUUM / RECOVERY SYSTEM SERVICE MAINTENANCE CHECKLIST

Whenever there is a vacuum problem, it's best to check over the entire system. Use the checklist below as a guide, to thoroughly check the vacuum system.

- Clean built-up dirt from the inside of the squeegee tool.
- Replace the squeegee blades if they are nicked or torn.
- Inspect the hose between the squeegee tool and the recovery tank, rinse any built-up dirt from the hose. Replace the hose if it is kinked or damaged.
- Inspect and make sure the gasket on the recovery tank cover is sealing and not damaged.
- Inspect and clean the vacuum motor screen.
- Make sure that the recovery tank drain valve seals airtight.
- Inspect and make sure the squeegee elbow bulb gasket on the bottom of the recovery tank seals and is not damaged.
- Inspect and make sure the (2) vacuum motor bulb gaskets on the bottom of the recovery tank are sealing and free from damage.

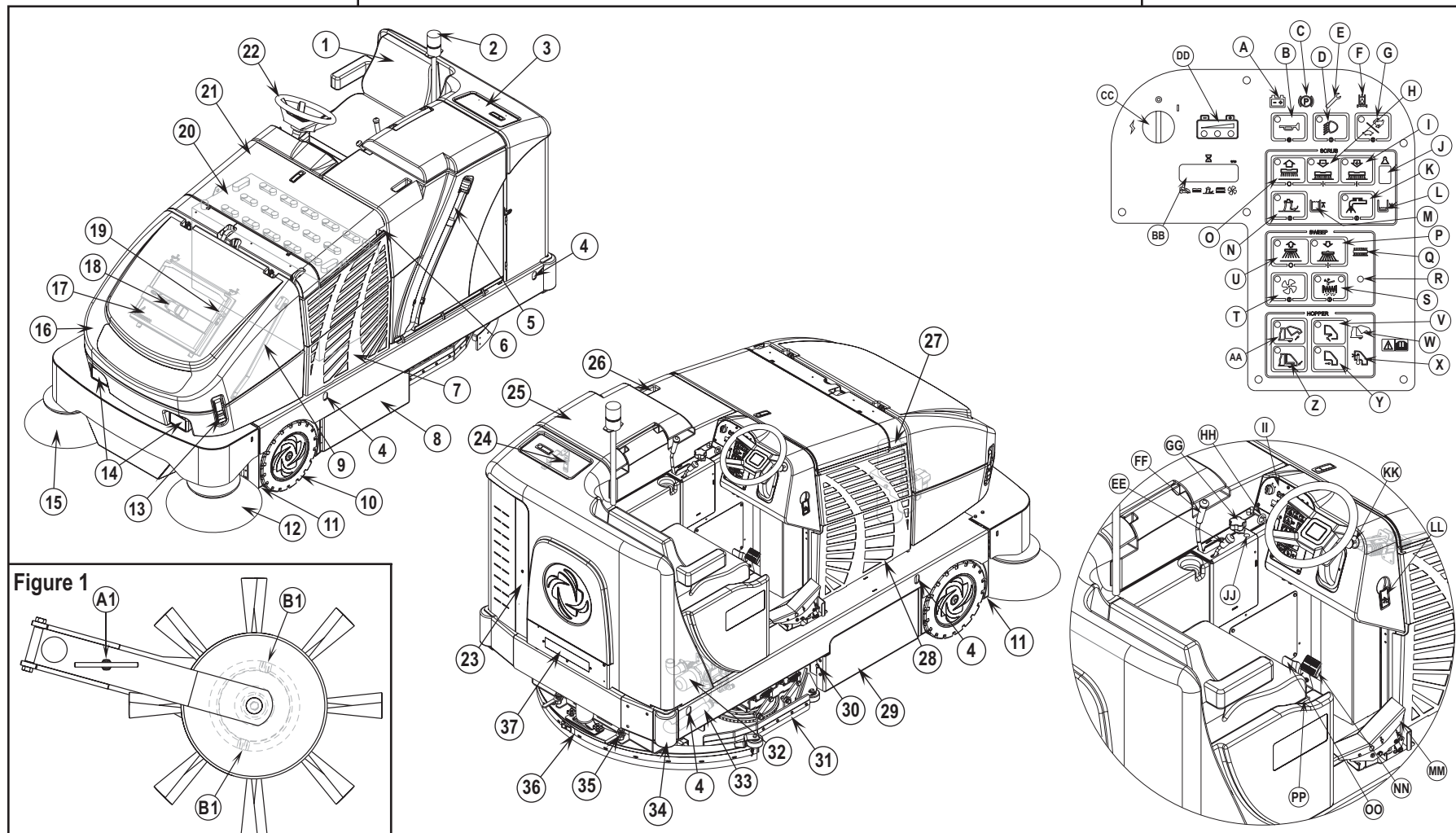

KNOW YOUR MACHINE

- 1 Operator's Seat
- 2 Strobe Light (optional / standard on Nilfisk Models)
- 3 Solution Tank Fill
- 4 Tie Down Locations
- 5 Recovery Tank Drain Hose
- 6 Recovery Tank Latch
- 7 Left Battery Compartment Access Panel
- 8 Main Broom Left Access Door
- 9 Hopper Cover Prop Rod
- 10 Front Wheel
- 11 Jacking Location
- 12 Left Side Broom
- 13 Hopper Cover Latch
- 14 Headlights
- 15 Right Side Broom
- 16 Hopper Cover
- 17 Dust Control Filter
- 18 Dust Control Shaker Assembly
- 19 Shaker Assembly Latch
- 20 Battery
- 21 Battery Compartment Door
- 22 Steering Wheel
- 23 Electrical Compartment Door
- 24 Water Level Gauge
- 25 Recovery Tank Lid
- 26 Recovery Tank "Tip-Out" Grip
- 27 Hydraulic Power Unit (Reservoir & Filter)
- 28 Right Battery Compartment Access Panel
- 29 Main Broom Right Access Door
- 30 Access Door Latch
- 31 Skirt Assembly
- 32 Inline Solution Filter
- 33 Solution Tank Drain Hose
- 34 Rear Roller Bumper
- 35 Squeegee Tool Handle
- 36 Squeegee Tool Assembly
- 37 Tail Light

CONTROL PANEL

- A Low Battery Indicator
- B Horn
- C Parking Brake Indicator (not used)
- D Headlights
- E Machine Needs Service Indicator
- F Hydraulic Filter Plugged Indicator
- G Speed Switch
- H Scrub Pressure Decrease Switch
- I Scrub Pressure Increase Switch
- J Scrub Pressure Display
- K Solution Switch
- L Solution Tank Empty Indicator
- M Recovery Tank Full Indicator
- N Vacuum System Switch
- O Scrub System OFF Switch
- P Side Broom ON
- Q Main Broom ON Indicator
- R Light Sensor
- S Shaker Switch
- T Dust Control Switch
- U Side Broom UP/OFF Switch
- V Open Dump Door Switch
- W Hopper Open Indicator
- X Hopper Overtemp Indicator
- Y Close Dump Door Switch
- Z Lower Hopper Switch
- AA Raise Hopper Switch
- BB Hour Meter Display
- CC Main Power Switch
- DD Battery Condition Indicator

OPERATOR'S COMPARTMENT

- EE Solution Flow Control Lever
- FF Main Broom Raise/Lower (ON/OFF) Lever
- GG Main Broom Adjust Knob
- HH Hopper Safety Support Lever
- II Control Panel
- JJ Main Broom Overload Indicator Light
- KK Emergency Battery Disconnect
- LL Tilt Wheel Lever
- MM Drive Pedal
- NN Brake Pedal
- OO Parking Brake Latch
- PP Operator Seat Adjustment Lever