

Operating instructions



**NEPTUNE 5-50 FA
SPECIAL**





Contents



| | | |
|--|--|-----|
| Symbols used to mark instructions | | 2 |
| 1 Important safety instructions | | 2 |
| 2 Description | 2.1 Purpose..... | 4 |
| | 2.2 Operating elements..... | 5 |
| 3 Before starting the cleaner | 3.1 Transport and assembly..... | 5 |
| | 3.2 Set the brake..... | 5 |
| | 3.3 Install Crank handle for high pressure hose reel/cord reel...6 | |
| | 3.4 Fill up detergent tanks..... | 6 |
| | 3.5 Fill up tank for Nilfisk-ALTO AntiStone (Anti-Scale).....6 | |
| | 3.6 Antiscale..... | 6 |
| | 3.7 Fill up fuel tank..... | 7 |
| | 3.8 Connecting the high pressure hose..... | 7 |
| | 3.9 Connecting the water supply..... | 8 |
| | 3.10 Electrical connection..... | 8 |
| | 3.11 Antifreeze - before first use..... | 8 |
| 4 Control / Operation | 4.1 Connections..... | 8 |
| | 4.2 Switching on the cleaner..... | 9 |
| | 4.3 Pressure regulation (Tornado Lance)..... | 9 |
| | 4.4 Pressure regulation (VarioPress Gun)..... | 9 |
| | 4.5 Using cleaning agents..... | 10 |
| 5 Applications and methods | 5.1 Techniques..... | 11 |
| | 5.2 Some typical cleaning tasks..... | 12 |
| 6 After using the cleaner | 6.1 Switching off the cleaner..... | 14 |
| | 6.2 Disconnecting supply lines..... | 14 |
| | 6.3 Rolling up the electrical lead and storing accessories..... | 14 |
| | 6.4 Storing the cleaner (below 0°C (32°F / Freezing)..... | 14 |
| 7 Maintenance | 7.1 Maintenance Schedule..... | 15 |
| | 7.2 Maintenance work..... | 15 |
| 8 Troubleshooting | 8.1 Indications on Display..... | 17 |
| | 8.2 Indication lights on control panel..... | 18 |
| | 8.3 Other Faults..... | 18 |
| 9 Further information | 9.1 Recycling the cleaner..... | 19 |
| | 9.2 Guarantee..... | 19 |
| | 9.3 EU Declaration of Conformity..... | 20 |
| | 9.4 Technical data..... | 502 |



Symbols used to mark instructions



Safety instructions in these operating instructions which must be observed to prevent risks to persons are marked with this danger symbol.



This indicates tips and instructions to simplify work and to ensure safe operation.



Before using the high-pressure cleaner, be sure to also read the enclosed operating instructions and keep them within reach at all times.



This symbol is used to mark safety instructions that must be observed to prevent damage to the machine and its performance.



Operations marked with this symbol should only be carried out by Nilfisk-ALTO Service Technicians.

1 Important safety instructions



For your own safety

The appliance must

- only be used by persons, who have been instructed in its correct usage and explicitly commissioned with the task of operating it.
- only be operated under supervision.
- not be used by children.
- not be used by mentally or physically disabled persons

Warning

- Ensure that any exhaust emissions are not in the vicinity of air intakes.
- This machine shall only be used with cleaning chemicals supplied or recommended by Nilfisk-ALTO. The use of other cleaning chemicals may adversely affect the safety of the machine.
- Risk of explosion – Do not use the cleaner to spray with flammable liquids.

General

Use of the high-pressure cleaner is subject to the applicable local

regulations.

Besides the operating instructions and the binding accident prevention regulations valid in the country of use, observe recognized regulations for safety and proper use.

Do not use any unsafe work techniques.

Do not tie the trigger handle open.

Transport

Transport of the high-pressure cleaner is easy on its large wheels.

For safe transport in and on vehicles we recommend preventing the equipment from sliding and tilting. Secure it with tie-downs and apply the parking brake on the castor wheel.

For transport at temperatures around or below freezing 0°C (32°F), anti-freeze should be drawn into the pump beforehand (see chapter 6).

Before starting the cleaner

If your 3-phase cleaner was supplied without a plug, have it fitted

with a suitable 3-phase plug with ground, by a qualified electrician. Before use, check that the high-pressure cleaner is safe and in proper condition.

Regularly check whether the power cord is damaged or shows signs of ageing.

Use the high-pressure cleaner only when the power cord is in a safe condition. (risk of electric shock using damaged cord!).

Check the rated voltage of the high-pressure cleaner before connecting it to the mains power supply. Ensure that the voltage shown on the rating plate corresponds to the voltage of the power supply.

We strongly recommend that the power supply to the high pressure cleaner be connected via a residual current circuit breaker. This device stops the supply of electricity if the leakage current to the ground exceeds 30 mA for 30 ms or it has an ground tester circuit.

Please observe the regulations and provisions applicable in your area. Before putting the high-pressure cleaner into service, carry out a visual check of all the

major components.

CAUTION!

High-pressure water jets can be dangerous if misused. The jet must not be directed at persons, animals, live electrical equipment or the cleaner itself.

Wear appropriate protective clothing and eye protection.

Do not direct the jet towards yourself or towards other persons in order to clean clothes or footwear.

During operation of the cleaner, recoil forces are produced at the gunvalve and spray lance and, when the spray lance is held at an angle, a torque is also created. The gunvalve and spray lance must therefore be held firmly in both hands.

Do not use the cleaner when other people without protective clothing are in the working area.

Check that cleaning will not result in dangerous substances (e.g. asbestos, oil) being washed off the object to be cleaned and harming the environment.

Do not clean delicate parts made of rubber, fabric, etc. with the 0° jet. Keep some distance between high pressure nozzle and surface in order to prevent the surface from damage. Do not use the high-pressure hose for lifting loads.

NOTE!

The maximum permissible working pressure and temperature are printed on the high-pressure hose.

Do not use the cleaner if the power cord or high-pressure hose is damaged.

Ensure adequate air circulation. Do not cover the cleaner or operate it in inadequately ventilated rooms!



Store the cleaner where it will not be exposed to frost or use antifreeze liquid!

Never operate the cleaner without water. Even brief shortages of water result in severe damage to the pump seals.

Water connection



This high pressure washer/cleaner is only allowed to be connected with the drinking water

mains, when an appropriate backflow preventer has been installed, Type BA according to EN 1717. If the back flow preventer hasn't been supplied, one can be purchased from your dealer. The length of the hose between the backflow preventer and the high pressure washer must be at least 12 metres (min diameter 3/4 inch) to absorb possible pressure peaks. Operation by suction (for example from a rainwater vessel) is carried out without backflow preventer. Contact your dealer for suction set recommendations.

As soon as water has flown through the BA valve, this water is not considered to be drinking water any more.

Operation

Keep cabinet and service door closed during operation.

CAUTION!

Unsuitable extension cords can represent a source of danger. Always unwind cord from the reels completely to prevent the power cord overheating.

Connectors and couplings of extension cords must be watertight.

Extension cords are not recommended, however if necessary refer to the following recommendations:

| Cord length m | Cross section | |
|---|---|--|
| | up to 16 A | up to 25 A |
| up to 20 m (US: 30 ft) (US: 50 ft) (US: 75 ft) | ø1.5mm ² 14 gauge 12 gauge 10 gauge | ø2.5mm ² 12 gauge 10 gauge not recommended |
| 20 to 50 m | ø2.5mm ² | ø4.0mm ² |

Do not damage the power cord (e.g. by driving over it, pulling or crushing it).

Disconnect the power cord by grasping the plug only (do not pull or tug the power cord).

CAUTION!

Unsuitable fuels (e.g. gasoline) must not be used as they can explode and catch fire.

Use clean fuel only, free of moisture and contamination. Contact your dealer for fuel source and type recommendations.

If the machine is to be operated at fuel stations or in other potentially hazardous areas, the machine may only be employed outside the hazard areas defined in the German „Technical Guidelines for Inflammable Fluids“ applicable at the point of use due to the potential explosion hazard posed by the burner.

If the machine is to be operated indoors, the local building regulations must be observed for the discharge of the exhaust fumes into the atmosphere. Ensure an adequate supply of fresh air.

If the machine is to be connected to a flue gas stack, then local building regulations must be observed. We will be glad to provide tips for connection systems, on request.

CAUTION!



Beware of hot water and steam discharge up to 150°C when operating in steam stage.

CAUTION!



Do not touch or cover the exhaust. Risk of burns and fire.



EN

Do not touch, cover or place hose or cord over the chimney. Danger for persons, risk of overheating and fire.

Electrical equipment

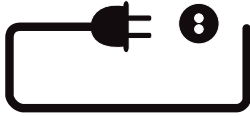

CAUTION!

Never spray electrical equipment with water: risk of electrical shock and short-circuit.

The cleaner may only be connected to a correctly installed plug socket.

Switching on the cleaner may cause voltage fluctuations. Voltage fluctuations should not occur if the impedance at the transfer point is less than 0.15Ω . If in doubt ask your local electricity supplier.

Maintenance and repair

Warning

The cleaner must be disconnected from its power source during cleaning of the machine, maintenance, when replacing parts or converting the machine to another function.

Carry out only the maintenance operations described in the operating instructions. Use only original Nilfisk-ALTO spare parts.

Do not make any technical modifications to the high-pressure cleaner.

Ensure that the machine is regularly serviced by authorized Nilfisk-ALTO dealers in accordance with the maintenance plan. Failure to do so will void the warranty.

CAUTION!

High-pressure hoses, fittings and couplings are important for the safety of the cleaner. Use only high-pressure parts approved by the manufacturer!

The power cord must not differ from the version specified by the manufacturer and may only be changed by an electrician. Please contact your local authorized Nilfisk-ALTO equipment distributor for all other maintenance or repair needs!

Testing

The cleaner conforms to the German „Guidelines for Liquid Spray Jet Devices“. The high-pressure cleaner must be subjected to a safety examination in accordance with the „Accident Prevention Regulations for Working with Liquid Spray Jet Devices“ as required, but at least every 12 months, by an authorised inspector.

After all repairs or modifications to electrical equipment, the protective conductor resistance, the insulation resistance and the leakage current must be measured. Furthermore, a visual inspection of the mains power cord, a voltage and current measurement and a function test must be carried out. Our after-sales service technicians are at your disposal as authorised inspectors.

The complete „Accident Prevention Regulations for Working with Liquid Spray Jet Devices“ are available from the Carl Heymanns Verlag KG, Luxemburger Strasse 449, 50939 Cologne or from the appropriate association of employers' liability insurances.

The pressure-bearing parts of this high-pressure cleaner have been manufactured in accordance with § 9 of the German Pressure Vessels Ordinance and successfully subjected to a pressure test.

Bypass valve

The pressure is reduced by means of a "bypass valve" which returns water to the inlet side of the pump at a minimum pressure. The point at which this occurs is set and sealed at the factory and must not be adjusted.

2 Description

2.1 Purpose

This high-pressure cleaner has been designed for professional use. It can be used for cleaning agricultural and construction equipment, stables, vehicles, rusty surfaces, etc.

The cleaner has not been approved for cleaning surfaces which comes into contact with food.

Chapter 5 describes the use of the high-pressure cleaner for various cleaning jobs.

Always use the cleaner as described in these operating instructions. Any other use may damage the cleaner or the surface to be cleaned or may result in severe injury to persons.

2.2 Operating elements



See fold-out page at front of these operating instructions.

- | | | | |
|----|---|----|---|
| 1 | Spray lance | 13 | Display (Temperature or Codes) |
| 2 | Spray lance storage | 14 | Temperature control |
| 3 | Control panel | 15 | Low fuel indicator |
| 4 | Crank handle for High pressure hose reel (Neptune ..X) ¹⁾ | 16 | Low Nilfisk-ALTO AntiStone (Anti-Scale) indicator |
| | Cord reel (Neptune ..X2) ¹⁾ | 17 | Service interval due/expired |
| 5 | Fuel level gauge | 18 | Pump oil low |
| 6 | Tank filler for fuel | 19 | Detergent metering knob |
| 7 | Receptacle for service crane and lifting ring ¹⁾ | 20 | Pressure gauge |
| 8 | Top cover release | 21 | Power ON |
| 9 | Service door release | 22 | Castor with parking brake |
| 10 | Crank handle for High pressure hose reel (Neptune ..X2) ¹⁾ | 23 | Water supply connection |
| 11 | High pressure hose connection for machines without hose reel | 24 | Tank filler for anti-freeze |
| 12 | Main switch ON/OFF - cold water/hot water | 25 | Tank filler for Nilfisk-ALTO Anti-Scale |
| | | 26 | Canister for detergent B ¹⁾ |
| | | 27 | High pressure hose reel (Neptune ..X) ¹⁾ |
| | | 28 | Power cord reel (Neptune ..X2) ¹⁾ |
| | | 29 | Tank filler for detergent A |
| | | 30 | Grip for top cover |



3 Before starting the cleaner

3.1 Transport and assembly

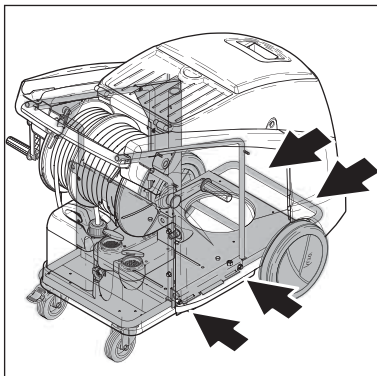

1. The safest way to lift the machine is to use a fork-lift truck. The arrows in the illustration indicate the best places to position the fork.
2. It is also possible to lift the ma-

chine by hand from the pallet. Due to the weight this work should be done by at least three persons.

CAUTION!

Do not hold the plastic tank to lift the machine as it could become detached from the frame.

The best places to hold the machine are

- on the handle
- on the frame between the front wheels and the guide rollers.

Every fuel-burning appliance, such as pressure washers, depends upon a proper mix of fuel and air (by weight) for proper combustion. Therefore some adjustment of the

air supply to the burner may be necessary to take account of altitude and the resulting air pressure. This is true whether your fuel is 'Natural gas', Propane or Diesel.

Your Nilfisk-ALTO hot water pressure washer was thoroughly tested and adjusted for optimum performance before it left our factory. The factory is located at approximately 120m (390 ft) above sea level, and the combustion settings are optimal for that elevation.

If your location is higher than 1200m (3900 ft) above sea level, your burner may require re-adjustment for proper performance and best fuel economy. Contact your Dealer or Nilfisk-ALTO for assistance.

3.2 Set the brake

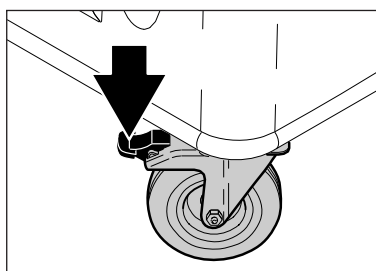

1. Before using the cleaner for the first time, check it carefully for any faults or damage.
2. Run the machine only when it is in perfect working condition.
3. Set the brake.
4. The slope on which the high pressure cleaner is placed must not exceed more than 10° in any direction.

¹⁾ Options / model variants



3.3 Install Crank handle for high pressure hose reel/cord reel

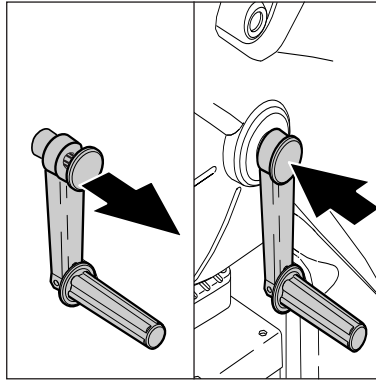

1. Pull cap of crank in arrow direction.
2. Align tabs on crank with slot in axle.
3. Put crank on axle of high pressure hose reel/cord reel.
4. Fix crank by pushing the cap.

3.4 Fill up detergent tanks

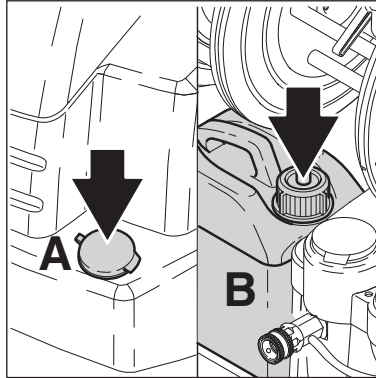

1. Fill up detergent tanks (A) and (B) with prediluted detergent. Capacity see chapter 9.4 Technical Data

3.5 Fill up tank for Nilfisk-ALTO AntiStone (Anti-Scale)

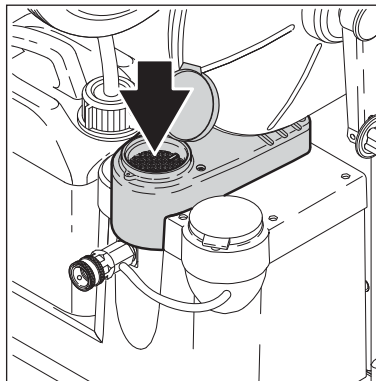

1. Fill up Nilfisk-ALTO Anti-Stone (Anti-Scale)/water softener reservoir with the sample bottle provided. Nilfisk-ALTO AntiStone (Anti-Scale) prevents any deposits of scale and acts at the same time as a corrosion inhibitor.

For compatibility reasons, use only the tested Nilfisk-ALTO AntiStone (Anti-Scale) which is available as a six-pack of 1 liter bottles by ordering part number 8466.

3.6 Antiscale

The Nilfisk Alto Antiscale dosing system is set by the factory. To adjust the water hardness we recommend that the inlet water is tested accordingly.

Use the schematic to find the right dosage of No Scale/anti stone and water, and add the mixture to the antiscala tank.

| Machine flow L/h | Pump size ml/h | °dH | °f | °e | Dosage |
|------------------|----------------|-------|-------------|-----------|---------------|
| 900 | 35 | 0-12 | 0-21,5 | 0 - 15 | 1:1 = 17ml/h |
| 900 | 35 | 12-30 | 21,5 - 53,7 | 15 - 37,5 | Pure = 35ml/h |
| 1000 | 35 | 0-12 | 0-21,5 | 0 - 15 | 1:1 = 17ml/h |
| 1000 | 35 | 12-30 | 21,5 - 53,7 | 15 - 37,5 | Pure = 35ml/h |

3.7 Fill up fuel tank

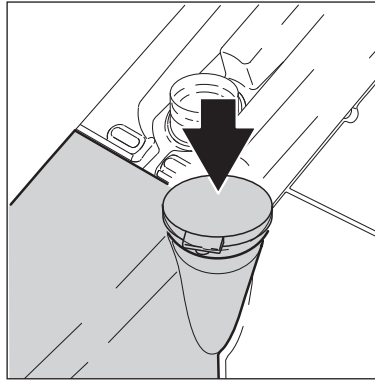

With the machine cold, turned off and disconnected from power supply:



1. Fill fuel tank from a clean container with a fresh fuel (fuel oil EL, or Diesel oil DIN 51 603), or fuel type recommended by your distributor.

The fuel must be free from contamination.

Tank capacity see chapter 9.4 Technical data.

NOTE!

At temperatures below 8°C (46°F), the fuel oil begins to solidify (paraffin precipitation). This can lead to difficulties in starting the burner. Before the winter

months it is recommended that a fuel conditioner/stabilizer be added (available from the fuel oil trade).

3.8 Connecting the high pressure hose

3.8.1 Machines with high pressure hose reel¹⁾

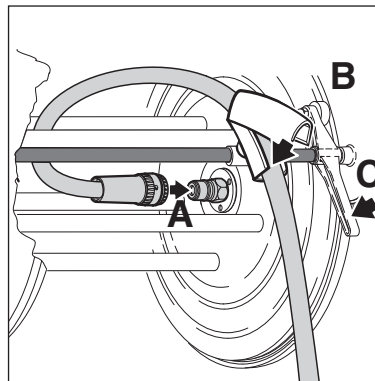

1. Connect the high pressure hose quick connector to the high pressure nipple (A) located at the hose reel axle.
2. Place the high pressure hose into the hose guide (B) and retain it with the clip.
3. Release the brake (C) on the hose reel and wind up the high pressure hose.

3.8.2 Machines without high pressure hose reel

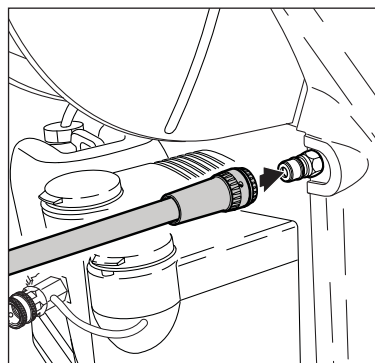

1. Connect the high pressure hose quick connector to the high pressure nipple located at right rear of machine above chemical tank.

¹⁾ Options / model variants



3.9 Connecting the water supply

NOTE!

See chapter 9.4 Technical Data for required quantity of water and water pressure.

In the case of poor water quality (sand, etc.), it is recommended that an inlet water filter be installed.

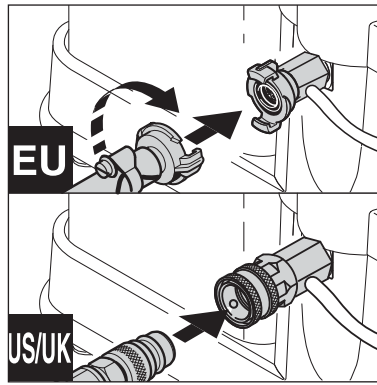

1. Attach quick connect adapter found with Owners Manual to the water supply hose.
2. Rinse the water supply hose briefly in order to prevent sand and other dirt particles entering into the machine.
3. Attach water supply hose with adapter to inlet quick connector.
4. Open water supply faucet. Water supply hose should be a reinforced hose and have a minimum inside diameter of **3/4" (19 mm)**.

3.10 Electrical connection

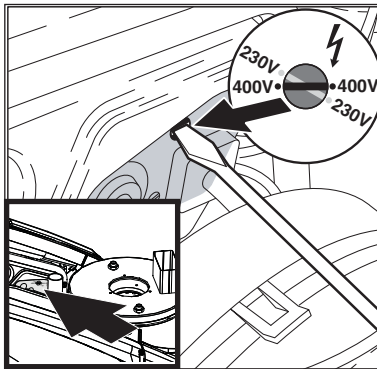

CAUTION!

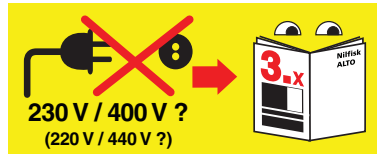

Some models have the ability to be used on either 230 Volt or a 440 Volt power supply. On these models confirm that the voltage selector switch is in the proper position to match the power supply. Otherwise damage to machines electrical components may occur.

CAUTION!

When using a cord reel:

1. Release brake of the cord reel.
2. Unwind the cord completely.

CAUTION!

The cleaner should only be connected to a correctly installed electrical supply.

1. Observe safety instructions in chapter 1.
2. Insert the plug into the electrical socket.

3.11 Antifreeze - before first use

The machine is flushed with antifreeze at the factory to protect it against freezing; this mixture (ap-

prox. 5 l) may be captured in a suitable container for reuse.

4 Control / Operation

4.1 Connections

4.1.1 Connecting the spray lance to the spray gun

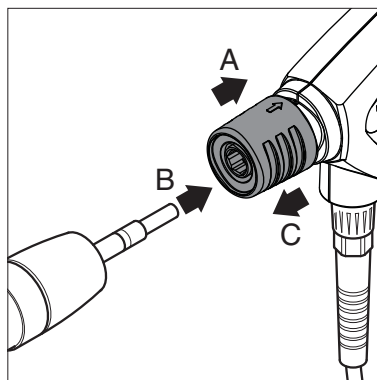

1. Pull the blue quick-release grip (A) of the spray gun backwards.
2. Insert the nipple of the spray lance (B) into the quick-release connection and release it.
3. Pull the spray lance (or other accessory) forwards to check that it is securely attached to the spray gun.



NOTE!

Always remove any dirt from the nipple before connecting the spray lance to the spray gun.

4.2 Switching on the cleaner

4.2.1 Cold water operation / Hot water operation (up to 100°C)

NOTE!

The cleaner switches off automatically twenty seconds after the spray gun has been closed. To start the cleaner again, squeeze the trigger and the machine will start automatically.

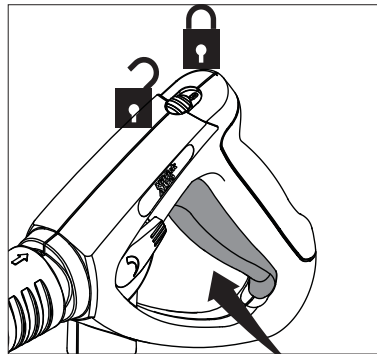
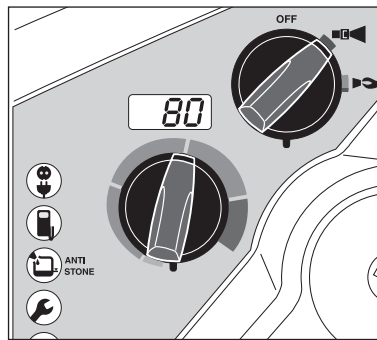

1. Turn the main switch to position (cold water).



Control electronics accomplishes a self check.

The Display shows for approx. 1 second „---“.

The motor starts.

is ON.

2. Turn the main switch to position (hot water).
3. Select temperature.
4. Unlock the spray gun and squeeze trigger.
5. The oil burner will light.
6. Release trigger and lock the spray gun when not in use.

4.2.2 Steam operation (over 100°C (212°F))



Beware of hot water and steam discharge up to 150°C when operating in steam stage.

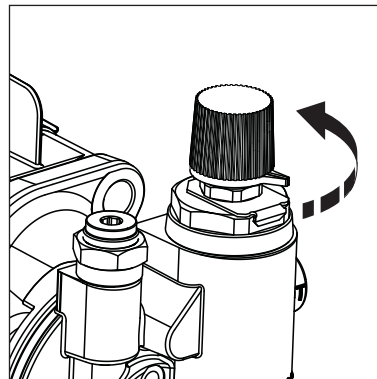

1. Open cabinet (and service door if desired - see chapter 3.6, Step 1+2).
2. Turn the twist grip on the safety control block all the way to the left (counter-clockwise-direction).
3. Turn the main switch to position .
4. Select temperature (over 100°C (212°F)).

For special applications: replace the standard nozzle with the steam spray nozzle (accessory).

4.3 Pressure regulation (Tornado Lance)

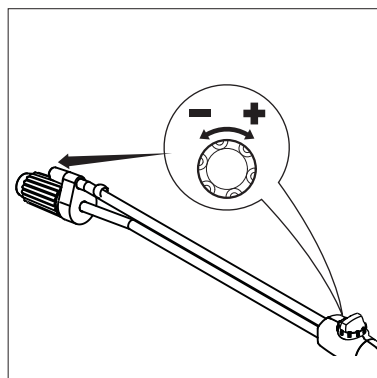

1. Turn the twist grip on the spray unit:

– High pressure = clockwise (+) for high pressure

– Low pressure = counter-clockwise (-) for low pressure.

4.4 Pressure regulation (VarioPress Gun)¹⁾



For safety reasons, never tie back or wedge open the trigger of the spray gun in open position during operation. The trigger must be free to close when released, thus interrupting the flow of the water.

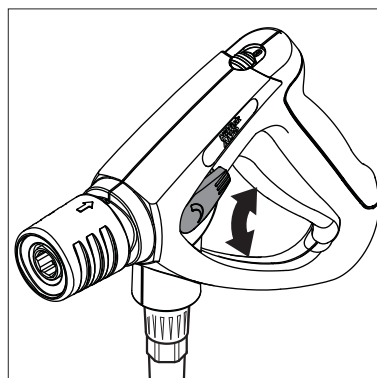

1. Turn the twist grip on the spray unit:

Water volume

(-) min. (+) max.

¹⁾ Options / model variants

EN

4.5 Using cleaning agents

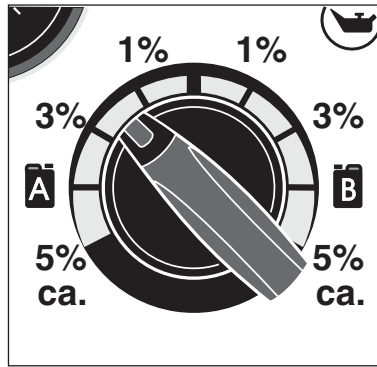
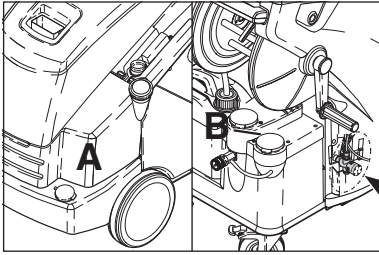

The percentage shown in the illustration are only approximate data.

For special applications such as disinfection, the exact detergent concentration has to be determined by using a graduated measuring container. For water outlet volume of the machine see chapter 9.4 technical data.

The use of cleaning agents while using the steam device will show a lower percentage and will result in a lower concentration.

1. Select desired detergent (A) or (B) and amount by turning the knob to desired percentage.
2. Spray the object to be cleaned.
3. Allow the cleaning agent to work, depending on the degree of soiling. Then rinse off with high pressure.

CAUTION!

Never allow cleaning agent to dry on the surface to be cleaned. The surface may be damaged.

5 Applications and methods

5.1 Techniques

Efficient high pressure cleaning is achieved by following a few guidelines, combined with your own personal experience of specific cleaning tasks. Accessories and detergents, when correctly chosen, can increase the efficiency of your pressure washer. Here is some basic information about cleaning.

5.1.1 Soaking

Encrusted or thick layers of dirt can be loosened or softened up by a period of soaking. This is for example an ideal method within agriculture – for example, within pig sties. The ideal soaking method can be achieved by using foam or simple alkaline detergent. Let the product lie on the dirty surfaces for about 30 minutes before pressure washing. The result will be a much quicker high pressure cleaning process.

5.1.2 Detergent and Foam

Foam or detergent should be applied onto dry surfaces so that the chemical product is in direct contact with the dirt. Detergents are applied from bottom to top, for example on a automobile bodywork, in order to avoid “super clean” areas, where the detergent may collect in higher concentrations and streams downwards. Let the detergent work for several minutes before rinsing before rinsing and never let it dry on the surface being cleaned.

5.1.3 Temperature

Detergents are more effective at higher temperatures. Greases, oils and fats can be broken down more effectively at higher temperatures also. Proteins can be cleaned at temperatures of around 60°C (140°F). Oils and traffic film around 70°C (158°F), and grease can be cleaned at 80°-90°C (176-194°F).

5.1.4 Mechanical Effect

In order to break down tough layers of dirt, additional mechanical effect may be required. Special lances and rotary or wash brushes offer this supplementary effect that cuts through dirt.

5.1.5 High Water Flow or High Pressure

High pressure is not always the best solution and may also damage surfaces. The cleaning effect also depends upon water flow. Pressure levels of around 100 bar (1450 psi) may be sufficient for vehicle cleaning (in association with hot water) and higher flow levels give the ability to rinse and flush away large amounts of dirt easily.



5.2 Some typical cleaning tasks

5.2.1 Agriculture

| Task | Accessories | Method |
|---|--|---|
| Stables Pig Pens, Sties Cleaning of walls, floors and equip- ment Disinfectant | Chemical Foam Injec- tors Foam lance Powerspeed lance Floor Cleaner Detergents Universal Alkafoam Disinfectant DES 3000 | <ol style="list-style-type: none"> 1. Soaking – apply foam to all surfaces (bottom to top) and wait for approx. 30 minutes. 2. Remove the dirt from surfaces with the high pressure lance or chosen accessory. Again, clean from bottom to top on vertical surfaces. 3. To flush away large quantities of dirt, change to low pressure mode and use the higher flow to push away the dirt. 4. Use recommended disinfectant products and methods to ensure hygiene. Apply DES 3000 disinfectant once the surfaces are perfectly clean. |
| Machinery Tractors ploughs etc. | Detergent injection Powerspeed lances Curved lances and un- derchassis washers Brushes | <ol style="list-style-type: none"> 1. Apply detergent to vehicle or equipment surfaces in order to soften up dirt and grime. Apply from bottom to top. 2. Proceed with cleaning using the high pressure lance. Clean again from bottom to top. Use accessories to clean in difficult to reach places. 3. Clean fragile areas such as motors, rubber at lower pressure levels to avoid damage. |

5.2.2 Vehicle

| Task | Accessories | Method |
|------------------|---|---|
| Vehicle bodywork | Standard lance Detergent injection Curved lances and un- derchassis washers brushes Detergents Active Shampoo Active Foam Sapphire Super Plus Aktive Wax Allosil RimTop | <ol style="list-style-type: none"> 1. Apply detergent to vehicle or equipment surfaces in order to soften up dirt and grime. Apply from bottom to top. In cases of particularly dirty vehicles, pre-spray with a product such as Allosil in order to remove traces of insects etc, then rinse at low pressure and apply normal car cleaning detergent. Let detergents settle for 5 minutes before cleaning off. Metallic surfaces can be cleaned using RimTop. 2. Proceed with cleaning using the high pressure lance. Clean again from bottom to top. Use accessories to clean in difficult to reach places. Use brushes in order to add a mechanical cleaning effect. Short lances can help for cleaning of motors and wheel arches. Curved lances or undercarriage washers can be valuable for the cleaning of car underchassis and wheel arches. 3. Clean fragile areas such as motors, rubber at lower pressure levels to avoid damage. 4. Apply a liquid wax using the pressure washer in order to protect the bodywork from pollution. |



5.2.3 Buildings and Equipment

| Task | Accessories | Method |
|---|--|--|
| General surfaces Metallic equipment | Foam injectors Standard lance Curved lances Tank cleaning head Detergents Intensive J25 Multi Combi Active Alkafoam Disinfectant DES 3000 | <ol style="list-style-type: none"> 1. Apply thick foam over the surfaces to be cleaned. Apply on dry surfaces. Apply from top to bottom on vertical surfaces. Let the foam act for up to 30 minutes for the optimal effect. 2. Proceed with cleaning using the high pressure lance. Use applicable accessories. Use high pressure to dislodge large amounts of incrustated dirt or grime. Use lower pressure and high water volume in order to rapidly flush away loose dirt and rinse surfaces. 3. Apply DES 3000 disinfectant once the surfaces are perfectly clean. <p>Areas covered by amounts of loose dirt, such as animal remains in slaughterhouses, can be removed by using high water flow to flush away the dirt to evacuation pits or drains.</p> <p>Tank cleaning heads can be used to clean barrels, vats, mixing tanks etc. Cleaning heads may be hydraulically or electrically powered and give the possibility for automatic cleaning without a constant user.</p> |
| Rusted or damages surfaces prior to treatment | Wet Sandblasting equipment | <ol style="list-style-type: none"> 1. Connect the sandblasting lance to the pressure washer and place the suction tube in the sand. 2. Always wear protective equipment during sandblasting. 3. Spray the surfaces to be treated with the mix of water and sand. Rust, paint etc will be stripped off. |

These are merely several examples of cleaning tasks that can be solved by a pressure washer in association with accessories and detergents. Each cleaning task is different. Please consult your local dealer or Nilfisk-ALTO representative in order to discuss the best solution for your own cleaning tasks.

EN 6 After using the cleaner

6.1 Switching off the cleaner

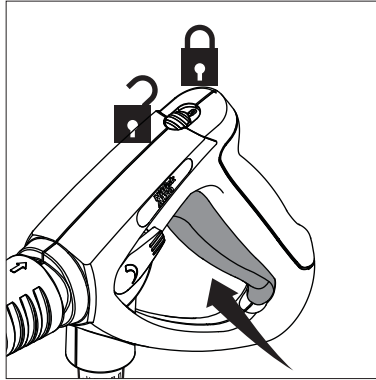

1. Turn the main switch to position „OFF“.
2. Turn off water supply at faucet.
3. Squeeze the spray gun trigger until the pressure has bled off.
4. Slide trigger lock to the locked position.

6.2 Disconnecting supply lines

1. Turn the main switch to position „OFF“.
2. Turn off water supply at faucet.
3. Squeeze the spray gun trigger until the pressure has bled off.

4. Slide trigger lock to the locked position.
5. Remove the water supply hose from the cleaner.
6. Remove power cord plug from the electrical supply.

6.3 Rolling up the electrical cord and storing accessories

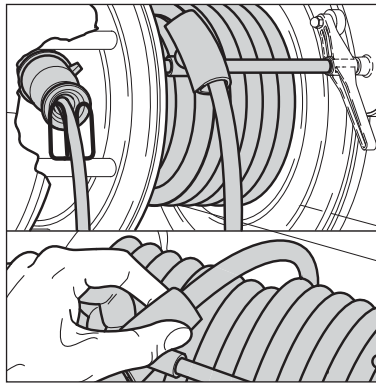

Risk of tripping!

To prevent accidents, always carefully roll up the power cord.

Machines with hose and/or cord reel:

1. Wind up the power cord as illustrated with the plug located in the center of the cord reel.
2. Wind up the high pressure hose as illustrated.
3. Place the spray lance into the spray lance storage.

6.4 Storing the cleaner (below 0°C (32°F))

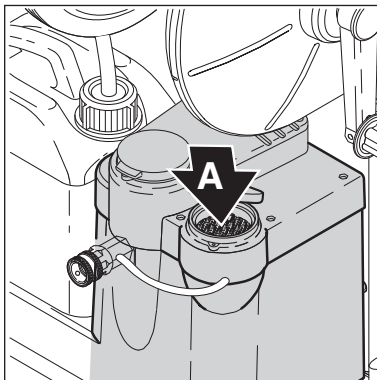

Store the cleaner in a dry heated location to protect against freezing or protect per below instructions:

1. Remove the water supply hose from the cleaner.
2. Remove the spray lance.
3. Switch on the cleaner with the main switch in position .
4. Squeeze trigger of the spray gun.
5. Gradually pour antifreeze (approx. 5 litres) into the water tank (A).
6. While the pump is pulling the mixture from the water tank,

squeeze and release the trigger two or three times.

7. The machine is protected against freezing when antifreeze mixture emerges from the spray gun.
8. Lock the safety catch on the spray gun.
9. Switch off the cleaner.
10. To avoid any possible damage, store the cleaner temporarily in a heated room before using it again.
11. When the machine is put into service again, the antifreeze solution can be collected and stored for future use.

7 Maintenance

7.1 Maintenance Schedule

| | Weekly | After the first 50 operating hours | Every six months or 500 operating hours | As required |
|-------------------------------------|--------|------------------------------------|---|-------------|
| 7.2.1 Water filters | | | | ● |
| 7.2.2 Oil filter | | | | ● |
| 7.2.3 Checking the pump oil quality | ● | | | |
| 7.2.4 Changing the pump oil | | ● | ● | |
| 7.2.5 Emptying the fuel oil tank | | | | ● |
| 7.2.6 Flame Sensor | | | | ● |

7.2 Maintenance work

7.2.1 Water filters

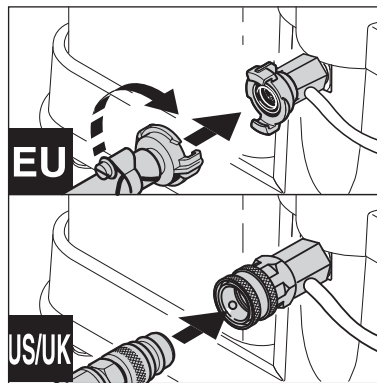

Water filters are fitted at the water and pump inlets to prevent large particles of dirt from entering into the system.

1. Unscrew quick coupling.
2. Remove filter with tool and clean it.

7.2.2 Maintenance of fuel filter

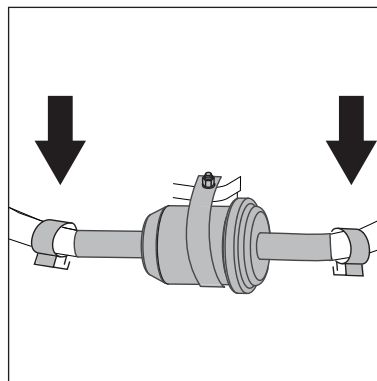

1. Open hose clips
2. Replace fuel filter
3. Close hose clips
4. Dispose the cleaning solution/damaged filter in accordance with the disposal regulations.



7.2.3 Checking the pump oil quality

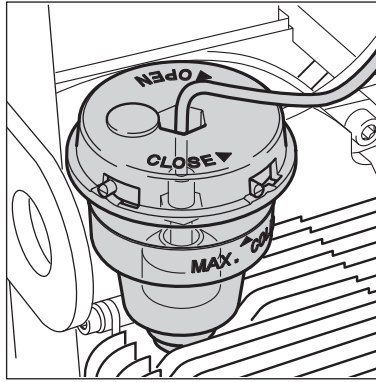

1. Check color of pump oil.
If the oil has a grey or white shade, change the oil (see chapter 7.2.4)
2. Top off oil level with fresh oil if necessary.
Oil type see chapter 9.4 Technical Data.

7.2.4 Changing the pump oil

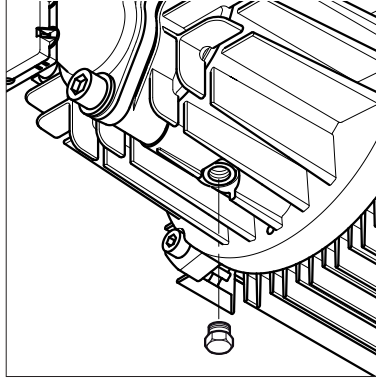

1. Unscrew the oil drain plug and drain oil into a suitable container.
2. Check that the drain plug gasket is in place and reinstall drain plug.
3. Fill pump with proper grade and amount of oil.
Oil grade and capacity see chapter '9.4 Technical Data'.

7.2.5 Emptying the fuel oil tank

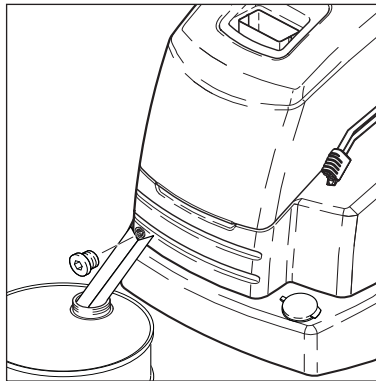

1. Prepare a container which is capable of containing the amount of fuel remaining in the tank.
2. Place drain channel beneath the drain plug.
3. Remove the drain plug and drain the fuel into the prepared container carefully not to spill fuel oil.
4. Check that the drain plug gasket is in place and reinstall drain plug.
5. Check tank and plug for leaks.



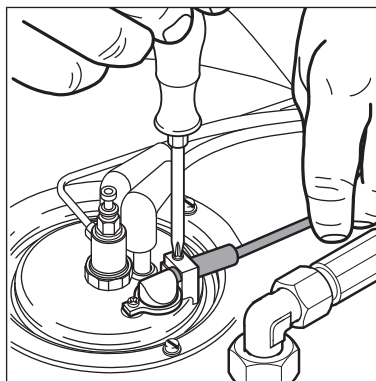







7.2.6 Flame sensor



1. Remove the sensor and clean with a soft cloth.
2. Confirm that the sensor is correctly seated when reinstalling.

8 Troubleshooting

8.1 Indications on Display

| Indication on Display | Cause | Remedy |
|--|--|---|
| FLF | > Flow sensor fault |  Contact Nilfisk-ALTO Service Cold water operation possible |
| FLO | > Water supply turned off or inadequate supply to machine > Detergent tank empty > Pressure regulation on the safety control block set to low water volume > Machine scaled | <ul style="list-style-type: none"> • Required volume flow and pressure see chapter 9.4 Technical Data • Fill detergent tank or set detergent metering to „OFF“ • Turn the twist grip on safety control block to higher water pressure/volume  Contact Nilfisk-ALTO Service |
| Fue  | > Fuel shortage | <ul style="list-style-type: none"> • Fill fuel tank Cold water operation possible |
| Hop | > Motor overheated | <ul style="list-style-type: none"> • Turn main switch in position „OFF“, let machine cool down • Remove extension cord, if being used. • Possible phase failure; have electrical connections checked |
| HOS | > Machine overheated |  Contact Nilfisk-ALTO Service |
| LEA | > Leakage or inadmissible operating condition by short-time operation > Spray gun leaking > High pressure hose, coupling or line system leaking > Detergent tank empty > Water inlet filter dirty > High-pressure pump drawing in air | <ul style="list-style-type: none"> • After three times of short-time operation the machine switches off. To reset: Turn main switch to position „OFF“, then start again. Keep trigger squeezed for longer than 3 seconds. If a leak occurs in the hose and gun and causes the machine to start and stop briefly 3 times, then the machine will switch off. • Repair Spray gun • Replace high-pressure hose, retighten screw fittings • Fill detergent tank or set detergent metering to „OFF“ • Clean filter (see chapter 7.2.1) • Repair leaks |
| LHE | > Flame sensor sooted > Ignition or fuel system failure | <ul style="list-style-type: none"> • Clean flame sensor (see chapter 7.2.6).  Contact Nilfisk-ALTO Service Cold water operation possible |
| LHL | > Burner failure |  Contact Nilfisk-ALTO Service Cold water operation possible |
| POL  | > Pump oil low | <ul style="list-style-type: none"> • Fill to proper level (see chapter 7.2.3) |
| SEC | > Temperature sensor damaged |  Contact Nilfisk-ALTO Service Cold water operation possible |
| SEO | > Temperature sensor damaged |  Contact Nilfisk-ALTO Service Cold water operation possible |
| UPC | > Microprocessor failure |  Contact Nilfisk-ALTO Service |



8.2 Indication lights on control panel

| Indication light | Cause | Remedy |
|------------------|---|---|
| flashing | > see FLO | • see FLO |
| ON | > Low fuel level | • Fill fuel tank • Cold water operation possible |
| ANTI STONE | > Low Nilfisk-ALTO AntiStone (Anti-Scale) level | • Fill Nilfisk-ALTO AntiStone (Anti-Scale) tank |
| flashing | > Service interval: Service due in 20 hours | Contact Nilfisk-ALTO Service |
| ON | > Service interval expired | Contact Nilfisk-ALTO Service |
| ON | > Pump oil low | • Fill to proper level |

8.3 Other Faults

| Fault | Cause | Remedy |
|---|--|--|
| not ON | > Power cord not properly connected to power supply | • Check power cord connection • Check fuse (see chapter 9.4 Technical Data) |
| Pressure too low | > High pressure nozzle worn out > Pressure regulation set to low pressure | • Replace nozzle • Turn the twist grip on safety control block clockwise (+) |
| Machine is running with pulsating pressure and makes knocking noise | > Pump has drawn in air due to detergent tank being empty | • Close detergent valve. Remove lance from gun. Operate spray gun and let machine run until air in pump is gone and the machine is running normally/ calm again. |
| No detergents drawn in | > Detergent tank empty > Dirt in detergent tank > Suction valve at cleaning agent inlet soiled | • Fill detergent tank • Clean detergent tank • Remove suction valve and clean or replace |
| Burner soots | > fuel contamination > Burner sooted or adjustment incorrect | Contact Nilfisk-ALTO Service |

9 Further information

9.1 Recycling the cleaner

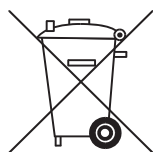

Make the old cleaner unusable immediately.

1. Unplug the cleaner and cut the power cord.

Do not discard of electrical appliances with household waste.

As specified in European Directive 2002/96/EC on old electrical

and electronic appliances, used electrical goods must be collected separately and recycled ecologically.

Contact your local authorities or your nearest dealer for further information.

9.2 Guarantee

Our general conditions of business are applicable with regard to the guarantee. Subject to change as a result of technical advances.

The guarantee is invalidated if the machine is not operated in accordance with these instructions or otherwise abused. The guarantee is invalidated if the machine is not serviced as described.

US only:

This warranty is in effect from the first day of purchase by the end user.

Each machine will have one (1) year coverage, from date of purchase by the end user, covering parts found defective due to faulty components, materials and/or bad workmanship. Not included in this warranty coverage are parts found defective due to:

- Normal wear and tear (such as seals, valves, pistons, bearings, etc.)
- Machine working under abnormal conditions.
- Machines being misused.

- Machines being repaired or tampered with by unauthorized person(s).

- The use of parts other than Nilfisk-ALTO Cleaning Systems, Inc. original spare parts and/or accessories.

The burner coil on all Nilfisk-ALTO Cleaning Systems, Inc. hot water/steam cleaners is under warranty for five (5) years against defects, and the high pressure hose is covered for an initial 30 days, under the same conditions described above.

Nilfisk-ALTO Cleaning Systems, Inc. will cover labor by an authorized Nilfisk-ALTO CSI Dealer for a 12-month period after the date of purchase of the machine by the end user.

No other costs, other than laid out in this warranty program, will be covered by the warranty.

Dated, End-User proof of purchase must be submitted with any claim for Warranty Service.

**9.3 EU Declaration of Conformity**

| EU Declaration of Conformity | |
|---|--|
| Product: | High Pressure Cleaner |
| Type: | NEPTUNE 5 |
| Description: | 400 V 3~ 50 Hz IPX5 400/230 V 3~ 50Hz IPX5 230-240 V 1~ 50Hz IPX5 |
| The design of the unit corresponds to the following pertinent regulations: | EC Machine Directive 2006/42/EC EC Low-voltage Directive 2006/95/EC EC EMC Directive 2004/108/EC |
| Applied harmonised standards: | EN ISO 12100-1, EN ISO 12100-2, EN 60335-2-79 EN 55014-1, EN 55014-2, EN 61000-3-2 |
| Applied national standards and technical specifications: | DIN EN 60335-2-79 |
| | Niifisk-Advance A/S Industrivej 1 DK-9560 Hadsund |
| Dipl. Ing. Wolfgang Nieuwkamp Tests and approvals | Hadsund, 01.06.2009 |



Technical Data

| NEPTUNE 5 | | | |
|---|--|------------------|----------------------|
| | | | 5-50 FA SPECIAL |
| Voltage 200 V / 3~ / 50Hz | | | |
| Voltage 200 V / 3~ / 60Hz | | | |
| Voltage 230 V / 1~ / 60Hz | | | |
| Voltage 400 V / 3~ / 50Hz | | | EU |
| Voltage 400/230 V / 3~ / 50Hz | | | |
| Voltage 220/440 V / 3~ / 60Hz | | | |
| Fuse | | A | 13 |
| Power rating | | kW | 6 / 6.1 |
| Power consumption | | A | 10.5 |
| Type of protection | | | IP X5 |
| Working pressure | | bar (Mpa) | 170/17 |
| Permissible pressure P_{max} | | bar (Mpa) | 250 |
| Volume flow (max) | | l/h | 960 |
| Volume flow Q_{IEC} | | l/h | 900 |
| High pressure nozzle | | | 0530 |
| Temperature t_{max} , hotwater | | °C | 90 |
| Temperature t_{max} , steam | | °C | 150 |
| Max. water inlet temperature | | °C | 40 |
| Max. water inlet pressure | | bar (Mpa) | 10(1) |
| Dimensions l x w x h | | mm | 1240 x 800 x 1185 |
| Weight | | kg | 179 |
| Calculated sound pressure at a distance of 1 m EN 60704-1 $L_{pA} +/- K_{pA}^*$ | | dB(A) | 77 +/- 1,5 |
| Sound power level $L_{WA,MAX}$ including $K_{WA} = 1,5dB^*$ | | dB(A) | 93 |
| Vibration ISO 5349 | | m/s ² | < 2 |
| Recoil forces | | N | 37/38 |
| Heating capacity | | kW | 78 |
| Fuel tank | | l | 35 |
| Detergent tank A / B | | l | 15/10 |
| Oil quantity | | l | 0.75 |
| Oil type | | | BP Energol GR-XP 220 |

* Noise emission acc. to EN 60335-2-79 ZAA.2.7

Nilfisk-ALTO
Division of Nilfisk-Advance A/S
Industrivej 1
DK - 9560 Hadsund
tel.: (+45) 7218 2100
www.nilfisk-ALTO.com

Nilfisk
ALTO
works for you