

IVB 7-M B1

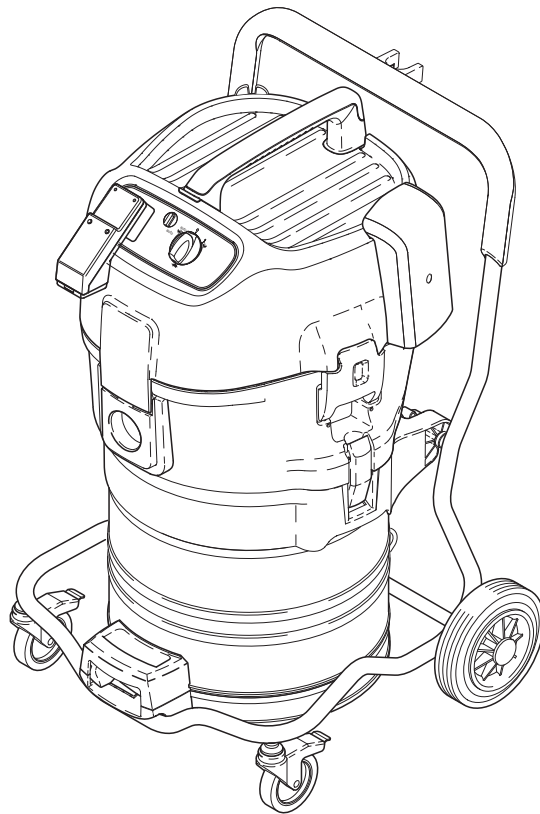

CE

302002028 B

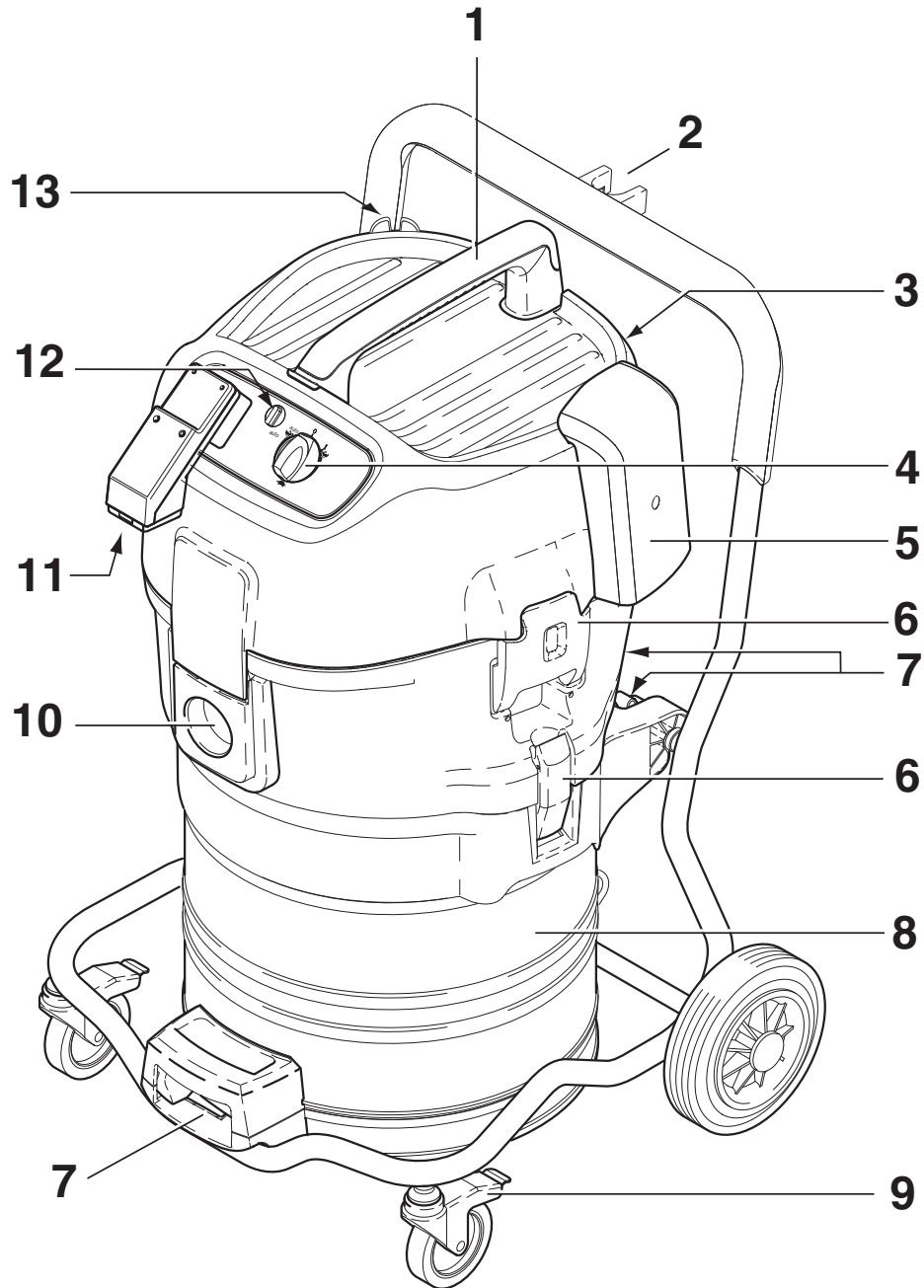

Contents



1 Important safety instructions	2
2 Description	2.1 Purpose	5
	2.2 Operating elements	5
3 Before start-up	3.1 Assembling the cleaner	5
4 Operation	4.1 Connections	5
	4.1.1 Connecting the suction hose	5
	4.1.2 Electrical connection	5
	4.1.3 Connecting electrical appliances	6
	4.2 Switching on the vacuum cleaner	6
	4.2.1 Switch position "I"	6
	4.2.2 Switch position „auto“	6
	4.2.3 Suction power control	6
	4.3 Check volume flow monitor	6
	4.4 Acoustic warning	7
5 Applications and techniques	5.1 Techniques	7
	5.1.1 Picking up dry substances	7
	5.1.2 Picking up liquids	7
6 After finishing work	6.1 Switching the vacuum cleaner off and storage	8
7 Maintenance	7.1 Maintenance plan	8
	7.2 Maintenance work	8
	7.2.1 Check the antistatic clamps	8
	7.2.2 Replacing the waste bag	9
	7.2.3 Replacing the filter bag	9
	7.2.4 Emptying the dirt tank	9
	7.2.5 Replacing filter element	10
	7.2.6 Replacing the filter for air supply to motor	10
8 Troubleshooting	11
9 Further information	9.1 Recycling the vacuum cleaner	12
	9.2 Guarantee	12
	9.3 Tests and approvals	12
	9.4 Technical data	13
	9.5 Accessories	13
	9.6 EC declaration of conformity	13

EN 1 Important safety instructions

Symbols used to mark instructions



available.

Before using the vacuum cleaner, always read the operating instructions and keep them readily



to the vacuum cleaner and its performance.

This symbol is used to mark safety instructions that must be observed to prevent damage



prevent damage to persons.

This symbol is used to mark safety instructions that must be observed to



operation.

This symbol indicates tips and instructions to

For your own safety

Only allow the vacuum cleaner to be used by persons who have been trained in its use and who have been explicitly authorized to use it.

The use of the vacuum cleaner is subject to valid national regulations. Besides the operating instructions and the binding accident prevention regulations valid in the country of use, observe recognized regulations for safety and proper use.

Despite its simple handling the vacuum cleaner is not suitable for children.

Do not use any unsafe work techniques.

Transport

Before transporting the dirt tank, close all the locks.

Do not use a crane hook to lift the cleaner.

Do not tilt the cleaner if there is liquid in the dirt tank.

Purpose and intended use

The vacuum cleaners described in this operating manual are suitable for

- commercial use, e.g. in hotels, schools, hospitals, factories, shops, offices and rental businesses
- for separation of dust with an exposure limit of greater than 1 mg/m³
- to pick up flammable, dry dust in zone 22 (ATEX regulation 94/9/EG,  II 3D T4 IP54)

gressive liquids (e.g. petrol, solvents, acids, alkalis, etc.)

- mixtures of flammable dusts with liquids
- explosive substances or substances considered to be similar in §1 of the law on explosives
- flammable dusts with an extremely low minimum ignition energy <1 mJ (also observe national regulations).
- Highly reactive dusts or dusts with a high affinity to oxygen

The following materials should not be picked up by the vacuum cleaner:

- hot materials (burning cigarettes, hot ash, etc.)
- flammable, explosive, ag-

For dusts like titanium and magnesium additional requirements apply, consult your national labour authorities or the manufacturer of the vacuum cleaner.



Use the cleaner only if it is certain that no active sources of ignition can be sucked in.

Conductive extraction equipment, e.g. extraction hoods on machines and conductive parts of machining equipment (e.g. equipment in protective class II) that are not earthed through the cleaner, must be earthed in some other way to prevent electrostatic charges.

The cleaner is not suitable for extraction on machining equipment in operation that could produce sources of ignition.

When dust removers are used,

Before start-up

Inspect power cord regularly to detect signs of damage, e.g. cracks or ageing.

If the power cord is damaged, it must be replaced by Nilfisk Advance Service or an electrician to avoid danger before use of the vacuum cleaner is continued.

Use only the type of power cord specified in the operating manual.

Do not damage the power cord (e.g. by moving over it or pulling or crushing it).

Disconnect the power cord by pulling the plug only (do not pull or tug the power cord).

Inspect the vacuum cleaners to ensure that they are in proper condition. Plugs and couplings in power cords must at least have splash protection.

Never use the vacuum cleaner if the filter element is damaged.

Picking up liquids

If foam develops or liquid emerges, stop work immediately and empty the dirt tank.

the rate at which air is exchanged in the room must be adequate if the exhaust air from the vacuum cleaner is blown into the room (please observe regulations valid in your country).

Before starting work, the operating staff must be informed on

- use of the vacuum cleaner
- risks associated with the material to be picked up
- safe disposal of the picked up material.

It must be assured that dust not accumulate on the appliance by regular cleaning.

Regularly clean the float that limits the water level and check it for damage.

See section 5 for information on handling liquids and (hazardous) dust.

Electrical components

Check the rated voltage of the vacuum cleaner before connecting it to the mains supply system. Ensure that the voltage shown on the rating plate corresponds to the voltage of the local mains power supply.

If you are using an extension cord, use only those specified by the manufacturer or higher quality ones (see section 9.4 „Technical data“).

It is recommended that the vacuum cleaner should be connected via a residual current circuit breaker. This stops the supply of electricity if the leakage current to earth exceeds 30 mA for 30 ms or it has an earth tester circuit.

When using an extension lead, check the minimum cross-sections of the cable:

Cable length m	Cross section	
	<16 A	<25 A
up to 20 m	ø1.5mm ²	ø2.5mm ²
20 to 50 m	ø2.5mm ²	ø4.0mm ²

Precautions and safety regulations when using the vacuum cleaner



	<p>Arrange the electrical parts (sockets, plugs and couplings) and lay down the extension lead so that the protection class is maintained.</p>	<p>short-circuiting.</p> <p>Observe the latest edition of the IEC regulations.</p>
	<p>Never spray water on to the upper section of the vacuum cleaner. Danger for persons, risk or</p>	
<p>Tool socket</p>	<p>Use the socket on the vacuum cleaner for the purpose defined in the operating instructions only.</p>	<p>be connected.</p>
	<p>Before plugging an appliance into the appliance socket:</p> <ol style="list-style-type: none"> 1. Switch off the vacuum cleaner 2. Switch off the appliance to 	<p>CAUTION! Follow the operating instructions and safety instructions for appliances connected to the power tool socket.</p>
<p>Maintenance, cleaning and repair</p>	<p>Only carry out maintenance work described in the operating instructions.</p>	<ul style="list-style-type: none"> – clean the outside of the vacuum cleaner, wipe it clean or pack the vacuum cleaner in well sealed packaging – and avoid spreading deposited harmful dust.
	<p>Always pull out the mains plug before cleaning and maintenance of the vacuum cleaner.</p>	<p>During maintenance and repair work all contaminated parts that could not be cleaned satisfactorily must be:</p> <ul style="list-style-type: none"> – packed in well sealed bags – disposed of in a manner that complies with valid regulations for such waste removal.
	<p>During maintenance and cleaning, handle the vacuum cleaner in such a manner that there is no danger for maintenance staff or other persons.</p>	<p>A dust test must be performed at least once every year by Nilfisk Advance Service or a trained person. This test includes, for example, whether there is damage to the filter, the vacuum cleaner is sealed to the air and the control equipment works properly.</p>
	<p>In the maintenance area</p> <ul style="list-style-type: none"> – use filtered compulsory ventilation – wear protective clothing – clean the maintenance area so that no harmful substances get into the surroundings. 	
	<p>Before removing the vacuum cleaner from the area contaminated with harmful substances:</p>	
<p>Accessories and spare parts</p>	<p>Use only the brushes supplied with the vacuum cleaner or specified in the operating manual. The use of other brushes can adversely affect safety.</p>	<p>Use only original Nilfisk-Advance accessories and spare parts (see section 9.5). The use of other parts can adversely affect safety.</p>

2 Description

- 2.1 Purpose** Depending on how hazardous the dust is, the cleaner must be fitted with appropriate filters. See table in section 5.1.1.
- 2.2 Operating elements** See fold-out page at the front of these operating instructions.
- | | |
|---|----------------------------------|
| 1 Handle | 5 Filter for air supply to motor |
| 2 Suction pipe support | 6 Retaining clamp |
| 3 Accessory holder | 7 Tank locks |
| 4 Appliance switch with suction power control | 8 Dirt tank |
| | 9 Castor with brake |
| | 10 Inlet fitting |
| | 11 Appliance socket |
| | 12 Hose diameter setting |
| | 13 Cable hook |

3 Before start-up

3.1 Assembling the cleaner



On delivery some of the accessories are lying in the tank and must be removed before the vacuum cleaner is used for the first time. Remove the upper section of the vacuum cleaner: The mains plug should not be inserted into a socket.

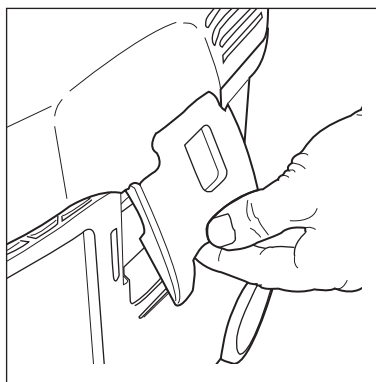

1. Open the retaining clamps and lift off the upper section of the cleaner.
2. Take the accessories out of the dirt tank and the packaging.

3. To pick up dust with maximum room concentration values: Insert the filter bag into the dirt tank according to the instructions (instructions included).

To pick up harmless dust: Insert the disposal bag (instructions included) into the tank.

IMPORTANT: Press the filter bag connection firmly on to the inlet fitting.

4. Fit the upper section of the vacuum cleaner and close the retaining clamps.

NOTE: Ensure that the retaining clamps fit properly.

4 Operation

4.1 Connections

4.1.1 Connecting the suction hose



The suction hose diameter must suit the position of the switch in order to pick up dry,

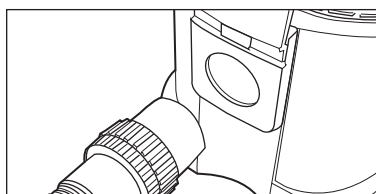

nonflammable dust with maximum room concentration values.

1. Connect the suction hose.

4.1.2 Electrical connection

The operating voltage shown on the rating plate must correspond to the voltage of the mains power supply.

Never use extension leads, couplings and adapter when picking up flammable dust.

1. **Ensure that the vacuum cleaner is switched off.**
2. Insert the power cord into a properly installed and fused socket with an earthing contact.



4.1.3 Connecting electrical appliances

To comply with regulations, only approved dust producing tools should be connected.

The maximum power consumption of the connected power tool is stated in section 9.4 "Technical data".

1. Ensure that the electrical appliance is switched off.
2. Connect the electrical appliance to the appliance socket on the control panel.

4.2 Switching on the vacuum cleaner

4.2.1 Switch position "I"

The hose diameter and the setting for the suction hose diameter must be the same.

Hose \varnothing	Hose diameter setting
$\varnothing 27$	$\varnothing 27$
$\varnothing 32$	$\varnothing 32$
$\varnothing 36$	$\varnothing 36$
$\varnothing 50$	$\varnothing 50$

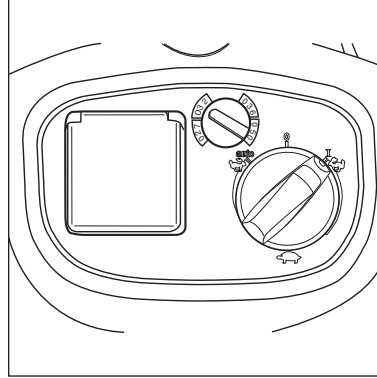

1. Turn the switch to position „I“.
- The vacuum cleaner motor starts.

4.2.2 Switch position „auto“

The hose diameter and the setting for the suction hose diameter must be the same.

Hose \varnothing	Hose diameter setting
$\varnothing 27$	$\varnothing 27$
$\varnothing 32$	$\varnothing 32$
$\varnothing 36$	$\varnothing 36$
$\varnothing 50$	$\varnothing 50$

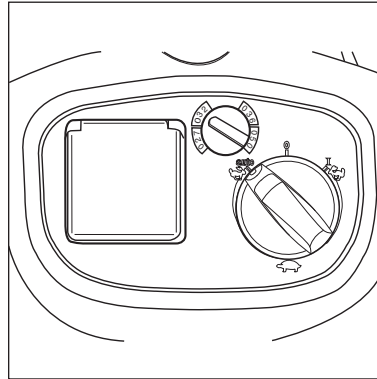

Before switching the switch to position „auto“, ensure that the tool connected to the appliance socket is switched off.

1. Turn the switch to position „auto“. The vacuum cleaner motor starts when the connected appliance is switched on.
2. When the power tool is switched off the vacuum cleaner continues to run for a short moment so that any dust in the suction hose is conveyed to the safety filter bag.

4.2.3 Suction power control

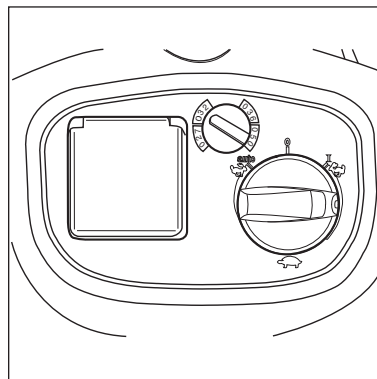

The motor speed and the suction power can be varied with the suction power control. This allows precise adaptation of the suction power for different cleaning tasks.

4.3 Check volume flow monitor

Before picking up dust with maximum room concentration values:

1. Check that all the filters, including the filter for supply air to the motor, are present,

properly fitted and not damaged.

2. When the motor is running, hold the suction hose shut. An acoustic warning sounds after approx. 1 second.



4.4 Acoustic warning

For safety reasons, an acoustic warning sounds if the air speed in the suction hose drops to below 20 m/s. See section "Troubleshooting".

5 Applications and techniques

5.1 Techniques

If used correctly, additional accessories, suction nozzles and suction hoses can enhance the cleaning action and reduce the cleaning effort.

Effective cleaning is achieved if you follow just a few guidelines in combination with your own practical experience in special fields.

Here are some basic tips.

5.1.1 Picking up dry substances



Do not pick up flammable substances.

The suction hose diameter must suit the position of the switch in order to pick up dry, nonflammable dust with maximum room concentration values.

There must always be a safety filter bag in the tank before dry substances with maximum room concentration values are picked up. See section 9.5 "Accessories" for ordering number.

To pick up harmless dust we recommend the use of a waste bag. See section 9.5 "Accessories" for ordering number. Dis-

posal of the picked up material is then simple and hygienic.

After picking up liquids, the filter element is wet. A damp filter element clogs more quickly when dry substances are picked up. For this reason the filter element should be washed and dried or replaced by a dry element before dry substances are picked up.

Always use a filter bag/waste bag that is suitable for the type of dust (see table):

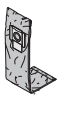
IVB 7-M B1		
Type of dust	Filter bag/waste bag	Handling/waste disposal
<ul style="list-style-type: none"> • Nonhazardous coarse dust • Dust with MAC values $\geq 1 \text{ mg/m}^3$ • Observe any additional national regulations 	 Waste bag No. 302001480	Waste disposal - see section 7.2.1
<ul style="list-style-type: none"> • Nonhazardous fine dust • Dust with MAC values $\geq 1 \text{ mg/m}^3$ • Explosive dust, explosion class St1, St2, St3 in zone 22 	 Filter bag No. 302002892	Waste disposal - see section 7.2.2

5.1.2 Picking up liquids



Do not pick up flammable substances.

Always remove the filter bag/waste bag before picking up liquids and check that the water level device functions properly (see section 7.2.5, "Replacing the filter element").

The use of a separate filter element or filter screen is recom-

mended.

If foam appears, stop work immediately and empty the tank.

To reduce the amount of foam, use foam killer Nilfisk-Alto Foam Stop (see section 9.5 "Accessories" for order number).

EN 6 After finishing work

6.1 Switching the vacuum cleaner off and storage

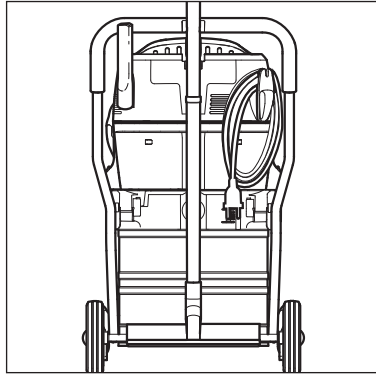

1. After picking up hazardous dust, vacuum clean the outside of the cleaner.
2. Switch off the vacuum cleaner and pull the mains plug out of the socket.
3. Wind up the power cord and hang it on the handle.
4. Empty the tank and clean the vacuum cleaner.
5. After picking up liquids: Store the upper section of the cleaner separately so that the filter element can dry.
6. Store the vacuum cleaner in a dry room where it is protected from unauthorized use.

7 Maintenance

7.1 Maintenance plan

		When replacing the filter bag, waste bag or filter element	After finishing work	As required
7.2.1	Check the antistatic Clamps	●		
7.2.2	Replacing the waste bag			●
7.2.3	Replacing the filter bag			●
7.2.4	Emptying the dirt tank		●	
7.2.5	Replacing filter element			●
7.2.6	Replace the filter for air supply to motor			●

7.2 Maintenance work

7.2.1 Check the antistatic clamps



Do not use the cleaner with damaged or missing antistatic clamps. Risk of explosion due to static discharge in explosive atmospheres.

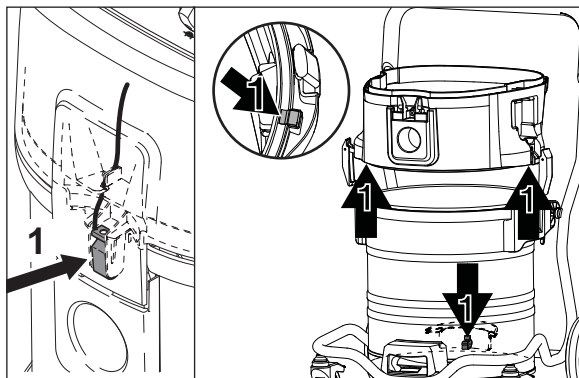

1. Check the antistatic clamps (1) for damage and have them replaced by Nilfisk Advance Service if necessary.

7.2.2 Replacing the waste bag



Only after picking up nonhazardous dust or dust with MAC values $>1 \text{ mg/m}^3$.

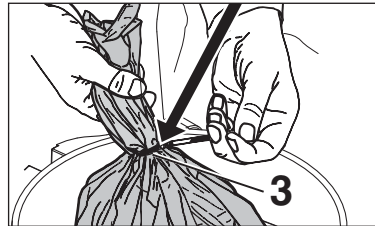
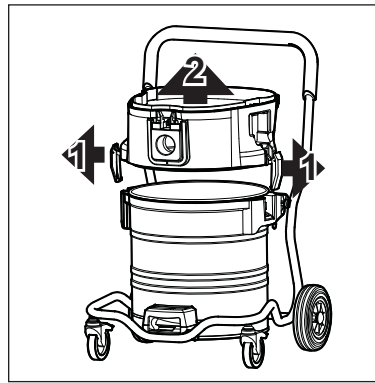

1. Remove the upper section of cleaner from the dirt tank.
2. Open the retaining clamps (1) and remove the intermediate ring (2) from the tank.
3. Close the waste bag using the cable binder (3).
4. Dispose of the dirt in accordance with legal regulations.
5. Insert a new filter bag into the cleaned tank as described in the instructions enclosed.

EN

7.2.3 Replacing the filter bag



During the following work, ensure that dust is not unnecessarily spread around. Wear a P2 breathing mask.

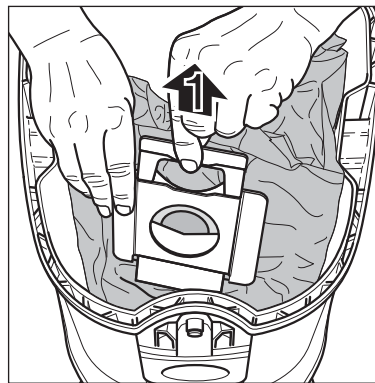

1. Open the retaining clamps and remove the upper section of the cleaner from the dirt tank.
2. Carefully remove the filter bag connection from the inlet fitting.
3. Close the filter bag connection with the slide.
4. Dispose of the filter bag in accordance with legal regulations.
5. Place a new filter bag into the cleaned tank as described in the instructions (printed on the filter bag)

IMPORTANT: Press the filter bag connection on the inlet fitting as far as possible.

7.2.4 Emptying the dirt tank



Only after picking up harmless dust without a filter bag.



To empty the dirt tank after picking up liquids: remove the intermediate ring as a proper seal is only ensured during suction. After emptying the tank: clean the rim of the tank and the seals in the intermediate ring and the upper section of cleaner before refitting them.

If the seal or groove is dirty or damaged, the suction performance will be reduced.

Before reinserting the suction hose: clean the inlet fitting and hose collar.

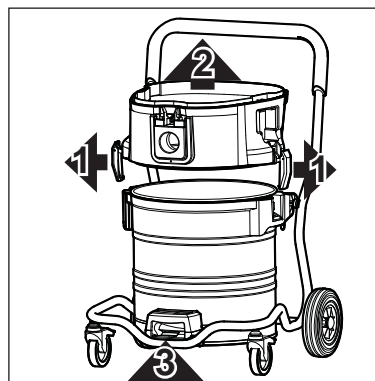

1. Remove the upper section of cleaner from the dirt tank.
2. Open the retaining clamps (1) and remove the intermediate ring (2) from the tank.
3. Pull the lever in the handle (3) upwards and tilt the tank.
4. Tip out the collected dirt.
5. Dispose of the dirt in accordance with legal regulations.

or:

3. Open the tank locks (4).
4. Use the handles (5) to lift the tank out of the frame.

EN

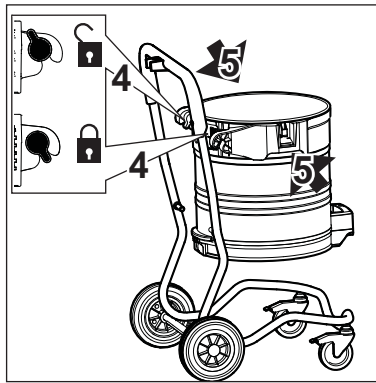
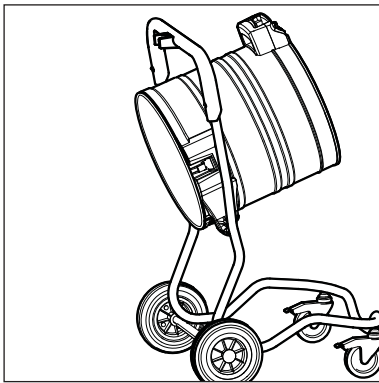

5. Tip out the collected dirt.
6. Place the empty tank in the frame and close the locks (4).
7. Dispose of the dirt in accordance with legal regulations.

7.2.5 Replacing filter element



During the following work, ensure that dust is not unnecessarily spread around. Wear a P2 breathing mask.

During the following work, ensure that dust is not unnecessarily spread around. Wear a P2 breathing mask.

1. Open the retaining clamps and remove the upper section of the cleaner from the dirt tank. Lay the upper section of the cleaner down with the filter element facing upwards.

2. Turn the filter holder anti-clockwise (1) and remove it (2).
3. Place the protective filter bag¹⁾ over the filter element (3).
4. Carefully remove the filter element and close the protective filter bag with a knot.
5. Clean the filter seal (4). Check it for damage and replace it if necessary.
6. Fit a new filter element.
7. Check that the float (5) works properly. When the filter holder is turned, the float inside must move about easily.
8. Fit the filter holder and turn it clockwise to secure it firmly.
9. Dispose of the used filter element in accordance with legal regulations.

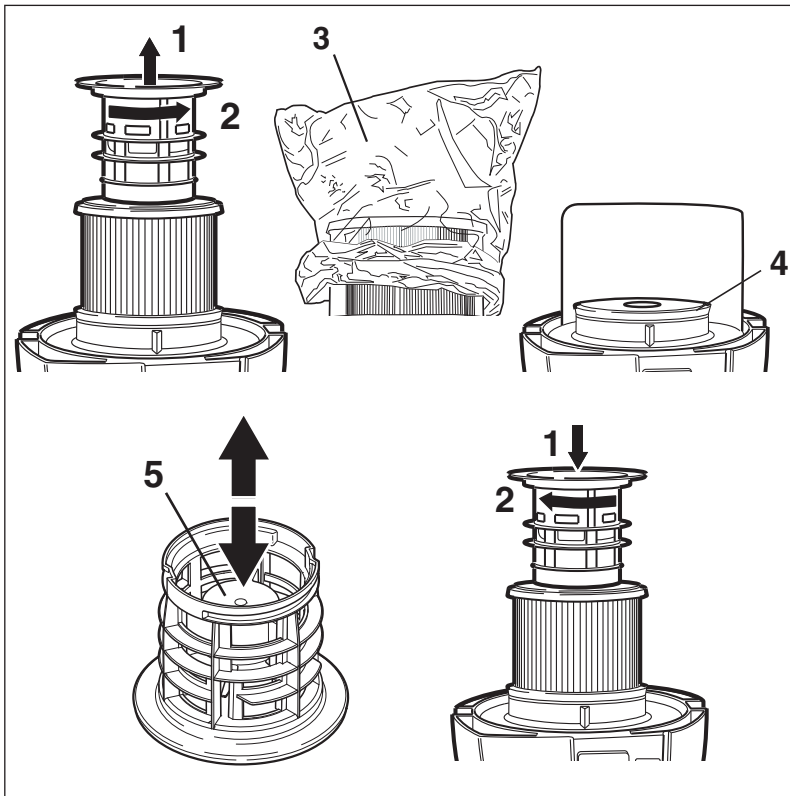

Never use the vacuum cleaner without a filter.

7.2.6 Replacing the filter for air supply to motor



mask.

During the following work, ensure that dust is not unnecessarily spread around. Wear a P2 breathing mask.

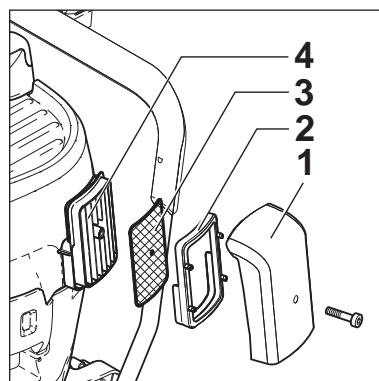

1. Loosen screws.
2. Remove the filter cassette (1).
3. Remove the frame (2) with filter felt (3) from the filter holder (4).
4. Insert new filter felt and fix it with frame.
5. Attach the filter cassette and insert the screw again.
6. Dispose of used filter felt in accordance with the regulations.

8 Troubleshooting

Fault	Cause	Remedy
‡ Motor does not start	<ul style="list-style-type: none"> > Fuse of the mains socket has blown. > Overload protection switch has tripped. 	<ul style="list-style-type: none"> • Connect mains fuse. • Switch off the vacuum cleaner and allow it to cool for approx. 5 minutes. If the cleaner cannot be started again, contact the Nilfisk Advance Service department.
‡ Motor does not run in automatic mode	<ul style="list-style-type: none"> > Power tool is defective or not connected properly. > The power rating of the electrical tool is too low. 	<ul style="list-style-type: none"> • Check that the power tool works or that the plug is inserted correctly. • Note that minimum power rating is P>40W
‡ The acoustic warning sounds. (Reduced suction power)	<ul style="list-style-type: none"> > Suction power selected with suction power control is too low. > Hose diameter and switch position do not correspond. > Clogged suction hose/nozzle. > Filter bag is full. > Filter element is clogged. 	<ul style="list-style-type: none"> • Set suction power in accordance with section 4.2.3. „Setting suction power“. • Set correct switch position for hose diameter. • Clean suction hose/nozzle • See section 7.2.2 „Replacing filter bag“. • See section 7.2.5 „Replacing filter element“.
‡ No suction power during wet cleaning	<ul style="list-style-type: none"> > Tank is full. (Float does not close the suction opening). 	<ul style="list-style-type: none"> • Switch off the cleaner. Empty the tank.
‡ The vacuum cleaner switches off during wet cleaning	<ul style="list-style-type: none"> > Tank is full. 	<ul style="list-style-type: none"> • Switch off the cleaner. Empty the tank.
‡ Voltage fluctuations	<ul style="list-style-type: none"> > Impedance of power supply is too high. 	<ul style="list-style-type: none"> • Connect the cleaner to another socket closer to the fuse box. Voltage fluctuations over 7% should not occur if the impedance at the transfer point is $\leq 0.15 \Omega$.

EN 9 Further information

9.1 Recycling the vacuum cleaner

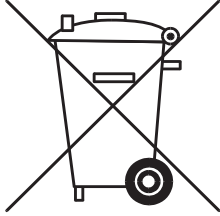

Make the old cleaner unusable immediately.

1. Unplug the cleaner and cut the power cord.

Do not discard of electrical appliances with household waste.

As specified in European Directive 2002/96/EC on old electrical

and electronic appliances, used electrical goods must be collected separately and recycled ecologically.

Contact your local authorities or your nearest dealer for further information.

9.2 Guarantee

Our general conditions of business are applicable with regard to the guarantee. Subject to change as a result of technical advances.

9.3 Tests and approvals

The vacuum cleaners have been tested as specified in IEC/EN 60335-2-69 including appendix AA. All the requirements were fulfilled for equipment in dust class M.

The cleaners fulfil the test requirements for dust explosion protection for industrial cleaners and dust extractors for use in zone 11, type 1.

Equally, the cleaners fulfil the requirements of the ATEX regulation 94/9/EG for use in zone 22. The vacuum cleaners must be inspected regularly in accordance with national accident prevention regulations (in Germany as specified in BGV A2 and DIN VDE 0701 Part 1 and Part 3, at regular intervals and after repairs or modifications).

A dust test must be performed at least once every year by the manufacturer or a trained person. This test covers, for example, whether there is damage to the filter, the vacuum cleaner is sealed to the air and the control equipment works properly.



9.4 Technical data

IVB 7-M B1				
		EU	GB 230V	GB 110V
Voltage	V	230	230	110
Mains frequency	Hz	50		
Fuse	A	16	13	16
Power consumption	W	1200		1000
Connected load for appliance socket	W	2400	1800	760
Total connected load	W	3600	3000	1760
Volume flow (air)	l/min	3600		
Negative pressure	Pa	23000		
Measurement area sound pressure level at a distance of 1 m, EN 60704-1	dB(A)	64		
Operating noise	dB(A)	59		
Power cord: Length	m	7.5		
Power cord: Length		H07RN- F3G1.5	H05RR- F3G1.5	H07BQ-F3G1.5
Protection class		I		
Type of protection (splash water protected)		IP X4		
Radio interference level		EN 55014-1		
Tank volume	l	70		
Width	mm	580		
Depth	mm	605		
Height	mm	970		
Weight	kg	25		

Suction hose diameter mm	Minimum air flow volume l/min	Associated negative pressure between suction hose/tool Pa
27	690	16300
32	970	15700
36	1220	14200
50	2360	7800

9.5 Optional Accessories

Description	Order No.
Filter bag (5 pcs.)	302002892
Waste bag (5 pcs.)	302001480
Filter element	302000490
Intake air filter (5 pcs.)	302001871
Protective filter bag (10 pcs.)	30082
Nilfisk-Alto-Foam-Stop (6 x 1 l)	8469

9.6 EC declaration of conformity

NILFISK-ADVANCE A/S Sognevej 25 DK-2605 Brøndby	
Product:	Vacuum cleaner for wet and dry operation
Model:	IVB 7-M B1
Description:	110/230-240 V~, 50/60 Hz, 1200 W, Dust class M, B1 ATEX Zone 22 II 3D T 135 °C IP 54
The design of this appliance complies with the following provisions:	EC - Machine directive 2006/42/EC EC - Directive EMC 2004/108/EC EC - Explosive Atmosphere directive 94/9/EC „ATEX“
Applied harmonized standards:	EN ISO 12100-1 (2004), EN ISO 12100-2 (2004), EN 55014-1 (2006), EN 55014-2 (2001), EN 61000-3-2 (2006), EN 1127-1 (2007), EN 61241-10 (2004)
Applied national standards and technical specifications:	EN 60335-2-69 (2004) IEC 60335-2-69 (2008)
 Anton Sørensen General Manager EAPC Technical Operations	Brøndby, 03.08.2009

