

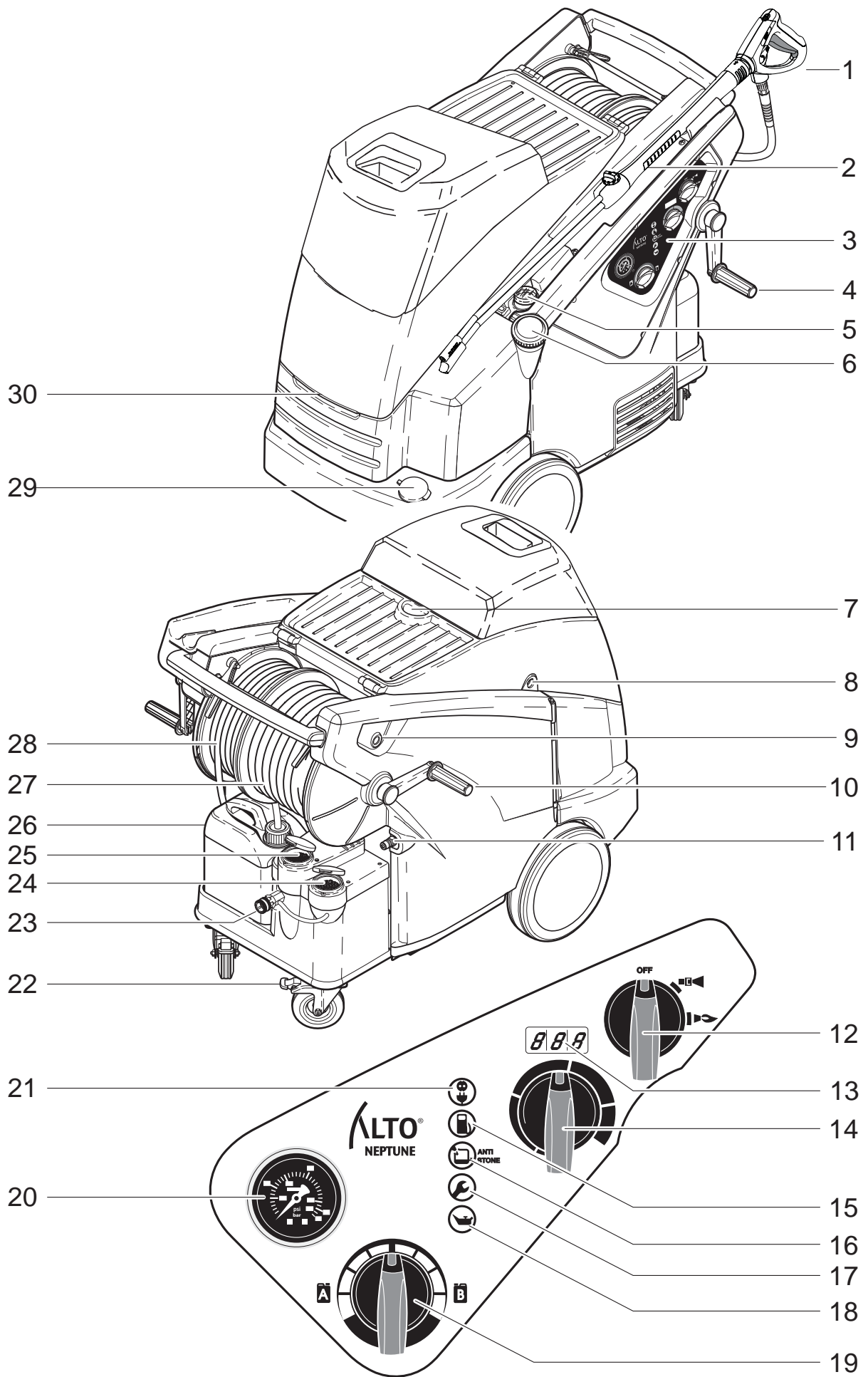

# NEPTUNE 7 FA Operating Instructions



**Nilfisk**  
**ALTO**  
*Why Compromise*



# Contents

<b>1</b>	<b>Important safety instructions.....</b>	<b>4</b>
	1.1 For your own safety .....	4
<b>2</b>	<b>Description .....</b>	<b>6</b>
	2.1 Purpose .....	6
	2.2 Operating elements .....	6
<b>3</b>	<b>Before starting the cleaner.....</b>	<b>7</b>
	3.1 Transport and assembly.....	7
	3.2 Combustion settings .....	7
	3.3 Set the brake .....	7
	3.4 Install Crank handle for high pressure hose reel/cord reel .....	8
	3.5 Fill up detergent tanks .....	8
	3.6 Fill up tank for Nilfisk-ALTO AntiStone (Anti-Scale) .....	8
	3.7 Antiscale .....	9
	3.8 Fill up fuel tank.....	9
	3.9 Connecting the high pressure hose .....	9
	3.10 Connecting the water supply .....	10
	3.11 Antifreeze - before first use.....	10
	3.12 Water connection .....	11
	3.13 Electrical connection.....	11
<b>4</b>	<b>Control / Operation .....</b>	<b>12</b>
	4.1 Operation .....	12
	4.2 Connections.....	12
	4.3 Switching on the cleaner.....	12
	4.4 Pressure regulation (Tornado Lance) .....	13
	4.5 Using cleaning agents .....	14
<b>5</b>	<b>Applications and methods .....</b>	<b>15</b>
	5.1 Techniques.....	15
	5.2 Some typical cleaning tasks .....	16
<b>6</b>	<b>Transport and storage .....</b>	<b>18</b>
	6.1 Transport.....	18
	6.2 Switching off the cleaner.....	18
	6.3 Disconnecting supply lines .....	18
	6.4 Rolling up the electrical cord and storing accessories.....	19
	6.5 Storing the cleaner below 0°C (32°F) .....	19
<b>7</b>	<b>Maintenance .....</b>	<b>20</b>
	7.1 Maintenance guidelines .....	20
	7.2 Maintenance schedule.....	20
	7.3 Maintenance work.....	20
<b>8</b>	<b>Troubleshooting .....</b>	<b>22</b>
	8.1 Indications on Display .....	22
	8.2 Indication lights on control panel .....	23
	8.3 Other Faults .....	23
<b>9</b>	<b>Further information .....</b>	<b>24</b>
	9.1 Recycling the cleaner .....	24
	9.2 Guarantee.....	24
	9.3 EU Declaration of Conformity .....	25
	9.4 Technical data.....	26

# 1 Important safety instructions

## 1.1 For your own safety

Prior to using the appliance for the first time, be sure to read this document through.

Besides the operating instructions and the binding accident prevention regulations valid in the country of use, observe recognised regulations for safety and proper use.

The appliance must

- only be used by persons, who have been instructed in its correct usage and explicitly commissioned with the task of operating it
- only be operated under supervision
- not be used by children
- not be used by mentally or physically disabled persons.



### CAUTION

- High pressure jets can be dangerous. Never direct the water jet at persons, pets, electrical equipment or the machine itself.
- Be aware when cleaning delicate parts made of rubber, fabric, etc. with the high pressure cleaner. Keep some distance between high pressure nozzle and surface in order to prevent the surface from damage.
- During operation of the cleaner, recoil forces are produced at the spraying device. It must therefore be held firmly in both hands.
- Wear goggles during operation.
- The operator and anyone in the immediate vicinity of the site of cleaning should take action to protect themselves from being struck by debris dislodged during operation.
- Never use the machine in an environment where there could be a danger of explosion.
- Risk of explosion – Do not use the cleaner to spray with flammable liquids.
- It is not allowed to clean asbestos-containing surfaces with high pressure.
- Check that cleaning will not result in dangerous substances (e.g. asbestos, oil) being washed off and harming the environment.
- Only use correct fuel as specified. Improper fuels can cause severe hazard.
- Ensure that any exhaust emissions are not in a vicinity of air intakes.
- Because of exhaust emissions, airborne dust and aerosols, use proper safety gear when necessary.
- Do not operate the cleaner in inadequately ventilated rooms.
- Do not touch, cover or place hose or power cord over the chimney.
- Do not tie the trigger handle open.
- Do not use any unsafe work techniques.
- Do not use the high-pressure hose for lifting loads.
- Operate the cleaner in the intended upright position only.
- High pressure hoses and couplings are safety relevant. Only use parts recommended by your Nilfisk ALTO dealer.

## 2 Description

- 2.1 Purpose** This high-pressure cleaner has been designed for professional use. It can be used for cleaning agricultural and construction equipment, stables, vehicles, rusty surfaces, etc.
- The cleaner has not been approved for cleaning surfaces which comes into contact with food.
- Always use the cleaner as described in these operating instructions. Any other use may damage the cleaner or the surface to be cleaned or may result in severe injury to persons.
- 2.2 Operating elements** See fold-out page at front of these operating instructions.
1. Spray lance, gun and hose
  2. Spray lance storage
  3. Control panel
  4. Crank handle for high pressure hose reel<sup>1)</sup>  
Cord reel<sup>1)</sup>
  5. Fuel level gauge
  6. Tank filler for fuel
  7. Receptacle for service crane and lifting ring<sup>1)</sup>
  8. Top cover release
  9. Service door release
  10. Crank handle for high pressure hose reel<sup>1)</sup>
  11. High pressure hose connection for machines without hose reel
  12. Main switch ON/OFF - cold water/hot water
  13. Display (Temperature or Codes)
  14. Temperature control
  15. Low fuel indicator
  16. Low Nilfisk-ALTO AntiStone (Anti-Scale) indicator
  17. Service interval due/expired
  18. Pump oil low
  19. Detergent metering knob
  20. Pressure gauge
  21. Power ON
  22. Castor with parking brake
  23. Water supply connection
  24. Tank filler for anti-freeze
  25. Tank filler for Nilfisk-ALTO Anti-Scale
  26. Canister for detergent B<sup>1)</sup>
  27. High pressure hose reel<sup>1)</sup>
  28. Power cord reel<sup>1)</sup>
  29. Tank filler for detergent A
  30. Grip for top cover

## 3 Before starting the cleaner

### 3.1 Transport and assembly

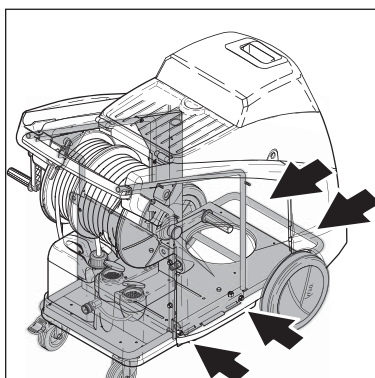

1. The safest way to lift the machine is to use a fork-lift truck. The arrows in the illustration indicate the best places to position the fork.
2. It is also possible to lift the machine by hand from the pallet. Due to the weight this work should be done by at least three persons.

#### CAUTION

Do not hold the plastic tank to lift the machine as it could become detached from the frame.

The best places to hold the machine are:

- on the handle
- on the frame between the front wheels and the guide rollers.

### 3.2 Combustion settings

Your Nilfisk-ALTO hot water pressure washer was thoroughly tested and adjusted for optimum performance before it left our factory. The factory is located at approximately 120m (390 ft) above sea level, and the combustion settings are optimal for that elevation.

If your location is higher than 1200m (3900 ft) above sea level, your burner may require re-adjustment for proper performance and best fuel economy. Contact your Dealer or Nilfisk-ALTO for assistance.

### 3.3 Set the brake

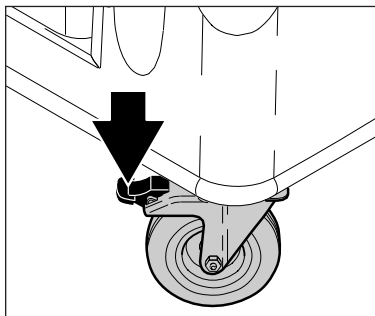

1. Before using the cleaner for the first time, check it carefully for any faults or damage.
2. Run the machine only when it is in perfect working condition.
3. Set the brake.
4. The slope on which the high pressure cleaner is placed must not exceed more than 10° in any direction.

### 3.4 Install Crank handle for high pressure hose reel/cord reel

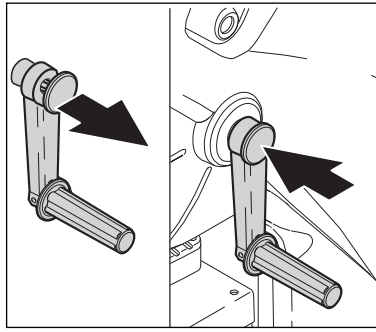

1. Pull cap of crank in arrow direction.
2. Align tabs on crank with slot in axle.
3. Put crank on axle of high pressure hose reel/cord reel.
4. Fix crank by pushing the cap.

### 3.5 Fill up detergent tanks

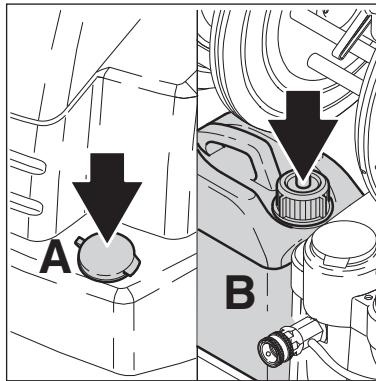

Fill up detergent tanks (A) and (B) with concentrated detergent.

### 3.6 Fill up tank for Nilfisk-ALTO AntiStone (Anti-Scale)

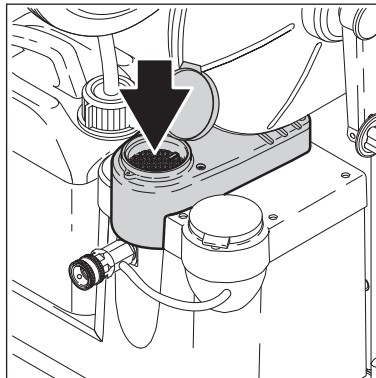

Fill up Nilfisk-ALTO Anti-Stone (Anti-Scale)/water softener reservoir with the sample bottle provided. Nilfisk-ALTO An-

tiStone (Anti-Scale) prevents any deposits of scale and acts at the same time as a corrosion inhibitor.

For compatibility reasons, use only the tested Nilfisk-ALTO AntiStone (Anti-Scale) which is available as:

- Six-pack of 1 liter bottles:  
order part number 8466
- 10 liter:  
order part number 80919
- 25 liter:  
order part number 81235

### 3.7 Antiscale

The Nilfisk ALTO Antiscale dosing system is set by the factory. To adjust the water hardness we recommend that the inlet water is tested accordingly.

Use the schematic to find the right dosage of No Scale/anti stone and water, and add the mixture to the antiscale tank.

Machine flow L/h	Pump size ml/h	°dH	°f	°e	Dosage
1200	35	0-12	0-21,5	0 - 15	1:1 = 17ml/h
1200	35	12-30	21,5 - 53,7	15 - 37,5	Pure = 35ml/h

### 3.8 Fill up fuel tank

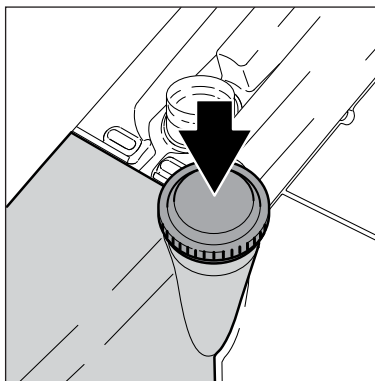

With the machine cold, turned off and disconnected from power supply:

- Fill fuel tank from a clean container with a fresh fuel (fuel oil EL, or Diesel oil DIN 51 603), or fuel type recommended by your distributor.

#### NOTE

- At temperatures below 8°C (46°F), the fuel oil begins to solidify (paraffin precipitation). This can lead to difficulties in starting the burner. Before the winter months it is recommended that a fuel conditioner/stabilizer be added (available from the fuel oil trade).
- Use clean fuel only, free of moisture and contamination. Contact your dealer for fuel source and type recommendations.

### 3.9 Connecting the high pressure hose

#### 3.9.1 Machines with high pressure hose reel<sup>1)</sup>

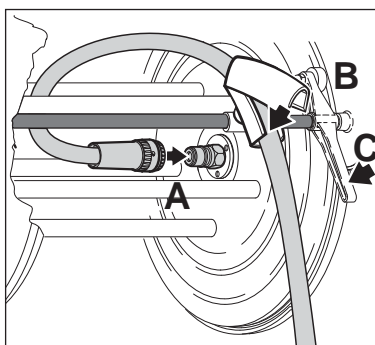

1. Connect the high pressure hose quick connector to the high pressure nipple (A) located at the hose reel axle.
2. Place the high pressure hose into the hose guide (B) and retain it with the clip.
3. Release the brake (C) on the hose reel and wind up the high pressure hose.

#### NOTE

- High-pressure hoses, fittings and couplings are important for the safety of the cleaner. Use only high-pressure parts approved by Nilfisk.

### 3.9.2 Machines without high pressure hose reel<sup>1)</sup>

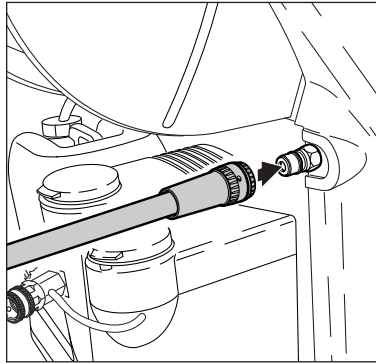

Connect the high pressure hose quick connector to the high pressure nipple located at right rear of machine above chemical tank.

### 3.10 Connecting the water supply

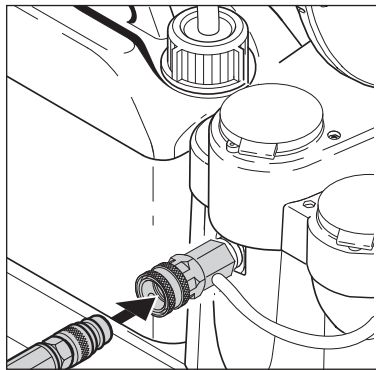

1. Attach quick connect adapter found with Owners Manual to the water supply hose.
2. Rinse the water supply hose briefly in order to prevent sand and other dirt particles entering into the machine.
3. Attach water supply hose with adapter to inlet quick connector.
4. Open water supply faucet.

#### NOTE

- See chapter 9.4 Technical Data for required quantity of water and water pressure.
- In the case of poor water quality (sand, etc.), it is recommended that an inlet water filter be installed.
- Water supply hose should be a reinforced hose and have a minimum inside diameter of 3/4" (19 mm).

#### CAUTION

- Never operate the cleaner without water. Even brief shortages of water result in severe damage to the pump seals.

### 3.11 Antifreeze - before first use

The machine is flushed with anti-freeze at the factory to protect it against freezing; this mixture (approx. 5 l) may be captured in a suitable container for reuse.

### 3.12 Water connection

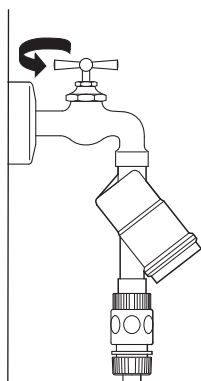

This high pressure washer/cleaner is only allowed to be connected with the drinking water mains, when an appropriate backflow preventer has been installed, Type BA according to EN 1717. If the backflow preventer hasn't been supplied, one can be ordered from your Nilfisk ALTO dealer. As soon as water has flown through the BA valve, this water is not considered to be drinking water any more. The length of the hose between the backflow preventer and the high pressure washer must be at least 12 metres (min diameter 3/4 inch) to absorb possible pressure peaks.

In the case of poor water quality (sand, etc.) add a water filter to the machine.

Rinse the water supply hose briefly in order to prevent sand and other dirt particles entering into the machine.

Operation by suction (for example from a rainwater vessel) is carried out without backflow preventer. Contact your Nilfisk ALTO dealer for suction set recommendations.

### 3.13 Electrical connection

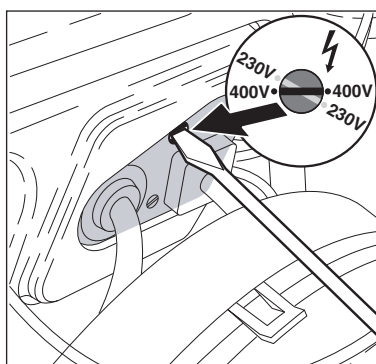

Some models have the ability to be used on either 230 Volt or a 440 Volt power supply. On these models confirm that the voltage selector switch is in the proper position to match the power supply. Otherwise dam-

age to machines electrical components may occur.

The following should be observed when connecting the high pressure washer to the electric installation:

- Only connect the machine to an installation with earth connection.
- The electric installation shall be made by a certified electrician.
- According to IEC 60364-1 it is strongly recommended that the electric supply to this machine should include a residual current device (GFCI).

#### CAUTION

- Do not damage the mains power lead, e.g. by driving over it, pulling or crushing it.
- Disconnect the power cord by pulling the plug only, do not pull or tug the power cord.

#### 3.13.1 Extension cables

*Cable connections should be kept dry and off the ground.*

Cables on drums should always be completely unwinded to prevent the cable from overheating. Extension cables should be of a watertight construction and comply with the below-mentioned requirements for length and cable dimensions.

Cable length m	Cross section	
	<16 A	<25 A
up to 20 m	ø1.5mm <sup>2</sup>	ø2.5mm <sup>2</sup>
20 to 50 m	ø2.5mm <sup>2</sup>	ø4.0mm <sup>2</sup>

## 4 Control / Operation

### 4.1 Operation

Before starting up the cleaner each time, please check it carefully for any defects. Always check for sufficient levels of fuel, oil and AntiScale. Also check the high pressure hose and gun, the insulation of the electric cable should be faultless and without any cracks.

#### NOTE

To achieve a long life and avoid problems with dirt in the gun and lance, the coupling and nipple have to be kept clean.

### 4.2 Connections

#### 4.2.1 Connecting the spray lance to the spray gun

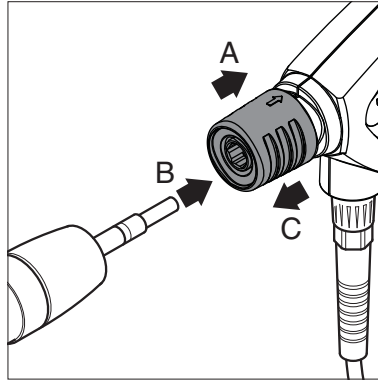

1. Pull the blue quick-release grip (A) of the spray gun backwards.
2. Insert the nipple of the spray lance (B) into the quick-release connection and release it.
3. Pull the spray lance (or other accessory) forwards to check that it is securely attached to the spray gun.

#### NOTE

Always remove any dirt from the nipple before connecting the spray lance to the spray gun.

### 4.3 Switching on the cleaner

#### 4.3.1 Cold water operation / Hot water operation (up to 100°C)

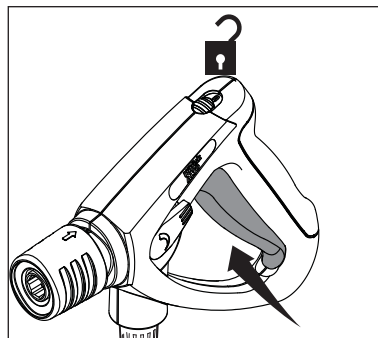
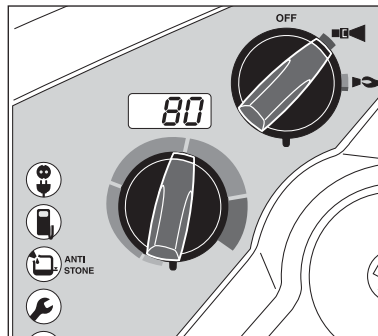

1. Turn the main switch to position (cold water).
  - Control electronics accomplishes a self check.
  - The Display shows for approx. 1 second „---“.
  - The motor starts.
  - is ON.
2. Turn the main switch to position (hot water).
3. Select temperature.
4. Unlock the spray gun and squeeze trigger.
5. The oil burner will light.
6. Release trigger and lock the spray gun when not in use.

**NOTE**

The cleaner switches off automatically twenty seconds after the spray gun has been closed. To start the cleaner again, squeeze the trigger and the machine will start automatically.

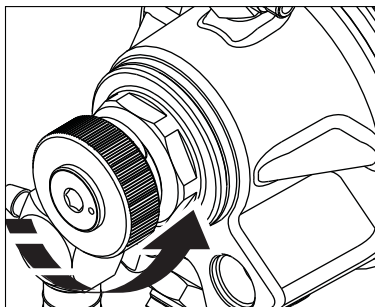
**4.3.2 Steam operation over 100°C (212°F)**

1. Open cabinet.
2. Turn the twist grip on the

safety control block all the way to the left (counter-clockwise-direction).

3. Turn the main switch to position .
4. Select temperature (over 100°C (212°F)).

For special applications: replace the standard nozzle with the steam spray nozzle (accessory).

**CAUTION**

Beware of hot water and steam discharge up to 150°C when operating in steam stage.

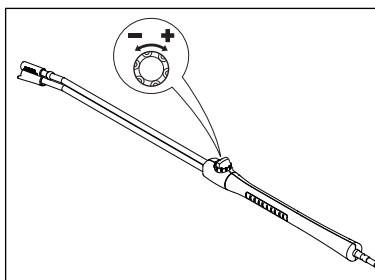
**4.4 Pressure regulation (Tornado Lance)**

1. Turn the twist grip on the spray unit:
  - High pressure = clockwise (+) for high pressure
  - Low pressure = counter-clockwise (-) for low pressure.

#### 4.5 Using cleaning agents

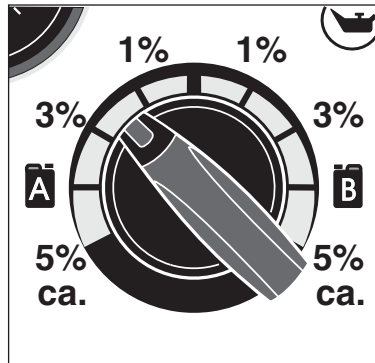
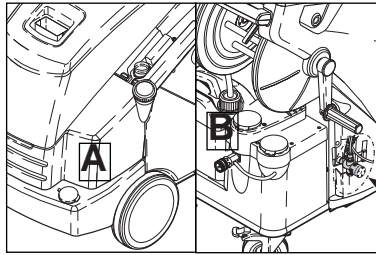

1. Select desired detergent (A) or (B) and amount by turning the knob to desired percentage.
2. Spray the object to be

cleaned.

3. Allow the cleaning agent to work.
4. Turn off the cleaning agent and spray until clean water is coming out of the lance.
5. Rinse off the object.

The percentage shown in the illustration are only approximate data.

For special applications such as disinfection, the exact detergent concentration has to be determined by using a graduated measuring container. For water outlet volume of the machine see chapter 9.4 technical data.

The use of cleaning agents while using the steam device will show a lower percentage and will result in a lower concentration.

#### NOTE

- Never allow cleaning agent to dry on the surface to be cleaned. The surface may be damaged.
- This machine shall only be used with cleaning chemicals supplied or recommended by Nilfisk ALTO.
- This machine will, when a cleaning agent has been chosen, spray out the detergent on high- as well as low-pressure.
- To lengthen the lifetime of the machine, make sure to flush the system with clean water after using chemicals.

# 5 Applications and methods

- 5.1 Techniques** Efficient high pressure cleaning is achieved by following a few guidelines, combined with your own personal experience of specific cleaning tasks. Accessories and detergents, when correctly chosen, can increase the efficiency of your pressure washer. Here is some basic information about cleaning.
- 5.1.1 Soaking** Encrusted or thick layers of dirt can be loosened or softened up by a period of soaking. This is for example an ideal method within agriculture – for example, within pig sties. The ideal soaking method can be achieved by using foam or simple alkaline detergent. Let the product lie on the dirty surfaces for about 30 minutes before pressure washing. The result will be a much quicker high pressure cleaning process.
- 5.1.2 Detergent and Foam** Foam or detergent should be applied onto dry surfaces so that the chemical product is in direct contact with the dirt. Detergents are applied from bottom to top, for example on a automobile bodywork, in order to avoid “super clean” areas, where the detergent may collect in higher concentrations and streams downwards. Let the detergent work for several minutes before rinsing and never let it dry on the surface being cleaned.
- 5.1.3 Temperature** Detergents are more effective at higher temperatures. Greases, oils and fats can be broken down more effectively at higher temperatures also. Proteins can be cleaned at temperatures of around 60°C (140°F). Oils and traffic film around 70°C (158°F), and grease can be cleaned at 80°-90°C (176-194°F).
- 5.1.4 Mechanical Effect** In order to break down tough layers of dirt, additional mechanical effect may be required. Special lances and rotary or wash brushes offer this supplementary effect that cuts through dirt.
- 5.1.5 High Water Flow or High Pressure** High pressure is not always the best solution and may also damage surfaces. The cleaning effect also depends upon water flow. Pressure levels of around 100 bar (1450 psi) may be sufficient for vehicle cleaning (in association with hot water) and higher flow levels give the ability to rinse and flush away large amounts of dirt easily.

## 5.2 Some typical cleaning tasks

### 5.2.1 Agriculture

Task	Accessories	Method
Stables Pig Pens, Sties  Cleaning of walls, floors and equip- ment  Disinfectant	Chemical Foam Injec- tors Foam lance Powerspeed lance Floor Cleaner  Detergents Universal Alkafoam  Disinfectant DES 3000	<ol style="list-style-type: none"> <li>1. Soaking – apply foam to all surfaces (bottom to top) and wait for approx. 30 minutes.</li> <li>2. Remove the dirt from surfaces with the high pressure lance or chosen accessory. Again, clean from bottom to top on vertical surfaces.</li> <li>3. To flush away large quantities of dirt, change to low pressure mode and use the higher flow to push away the dirt.</li> <li>4. Use recommended disinfectant products and methods to ensure hygiene. Apply DES 3000 disinfectant once the surfaces are perfectly clean.</li> </ol>
Machinery Tractors ploughs etc.	Detergent injection Powerspeed lances Curved lances and underchassis washers Brushes	<ol style="list-style-type: none"> <li>1. Apply detergent to vehicle or equipment surfaces in order to soften up dirt and grime. Apply from bottom to top.</li> <li>2. Proceed with cleaning using the high pressure lance. Clean again from bottom to top. Use accessories to clean in difficult to reach places.</li> <li>3. Clean fragile areas such as motors, rubber at lower pressure levels to avoid damage.</li> </ol>

### 5.2.2 Vehicle

Task	Accessories	Method
Vehicle bodywork	Standard lance Detergent injection Curved lances and underchassis washers brushes  Detergents Active Shampoo Active Foam Sapphire Super Plus Aktive Wax Allosil RimTop	<ol style="list-style-type: none"> <li>1. Apply detergent to vehicle or equipment surfaces in order to soften up dirt and grime. Apply from bottom to top. In cases of particularly dirty vehicles, pre-spray with a product such as Allosil in order to remove traces of insects etc, then rinse at low pressure and apply normal car cleaning detergent. Let detergents settle for 5 minutes before cleaning off. Metallic surfaces can be cleaned using Rim-Top.</li> <li>2. Proceed with cleaning using the high pressure lance. Clean again from bottom to top. Use accessories to clean in difficult to reach places. Use brushes in order to add a mechanical cleaning effect. Short lances can help for cleaning of motors and wheel arches. Curved lances or undercarriage washers can be valuable for the cleaning of car underchassis and wheel arches.</li> <li>3. Clean fragile areas such as motors, rubber at lower pressure levels to avoid damage.</li> <li>4. Apply a liquid wax using the pressure washer in order to protect the bodywork from pollution.</li> </ol>

### 5.2.3 Buildings and Equipment

Task	Accessories	Method
General surfaces  Metallic equipment	Foam injectors, foam lances, standard lances Curved lances Tank cleaning head  Detergents Intensive J25 Multi Combi Active Alkafoam  Disinfectant DES 3000	<ol style="list-style-type: none"> <li>1. Apply thick foam over the surfaces to be cleaned. Apply on dry surfaces. Apply from top to bottom on vertical surfaces. Let the foam act for up to 30 minutes for the optimal effect.</li> <li>2. Proceed with cleaning using the high pressure lance. Use applicable accessories. Use high pressure to dislodge large amounts of incrustated dirt or grime. Use lower pressure and high water volume in order to rapidly flush away loose dirt and rinse surfaces.</li> <li>3. Apply DES 3000 disinfectant once the surfaces are perfectly clean.</li> </ol> <p>Areas covered by amounts of loose dirt, such as animal remains in slaughterhouses, can be removed by using high water flow to flush away the dirt to evacuation pits or drains.</p> <p>Tank cleaning heads can be used to clean barrels, vats, mixing tanks etc. Cleaning heads may be hydraulically or electrically powered and give the possibility for automatic cleaning without a constant user.</p>
Rusted or damages surfaces prior to treatment	Wet Sandblasting equipment	<ol style="list-style-type: none"> <li>1. Connect the sandblasting lance to the pressure washer and place the suction tube in the sand.</li> <li>2. Always wear protective equipment during sandblasting.</li> <li>3. Spray the surfaces to be treated with the mix of water and sand. Rust, paint etc will be stripped off.</li> </ol>

These are merely several examples of cleaning tasks that can be solved by a pressure washer in association with accessories and detergents. Each cleaning task is different. Please consult your local dealer or Nilfisk-ALTO representative in order to discuss the best solution for your own cleaning tasks.

## 6 Transport and storage

### 6.1 Transport

For safe transport in and on vehicles we recommend to prevent the equipment from sliding and tilting by fixing it with belts.

Transport:

- Do not tilt the machine.
- Run the machine to empty the break tank and de pressurise the high pressure hose by squeezing the trigger.

For transport and storage at temperatures around or below 0°C, anti-freeze liquid should be drawn into the pump beforehand.

### 6.2 Switching off the cleaner

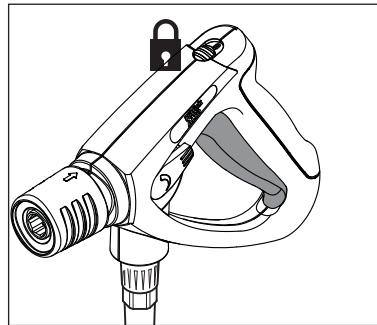

1. Turn the main switch to position „OFF“.
2. Turn off water supply at faucet.
3. Squeeze the spray gun trigger until the pressure has bled off.
4. Slide trigger lock to the locked position.

### 6.3 Disconnecting supply lines

1. Turn the main switch to position „OFF“.
2. Turn off water supply at faucet.
3. Squeeze the spray gun trigger until the pressure has bled off.
4. Slide trigger lock to the locked position.
5. Remove the water supply hose from the cleaner.
6. Remove power cord plug from the electrical supply.

#### 6.4 Rolling up the electrical cord and storing accessories

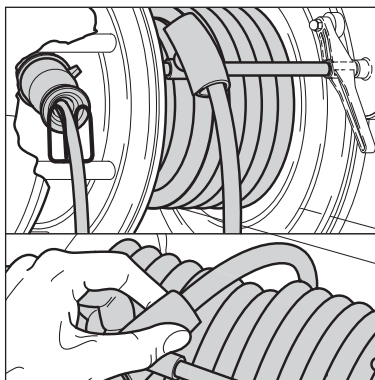

#### Risk of tripping

To prevent accidents, always carefully roll up the power cord.

Machines with hose and cord reel:

1. Wind up the power cord as illustrated with the plug located in the center of the cord reel.
2. Wind up the high pressure hose as illustrated.
3. Place the spray lance into the spray lance storage.

#### 6.5 Storing the cleaner below 0°C (32°F)

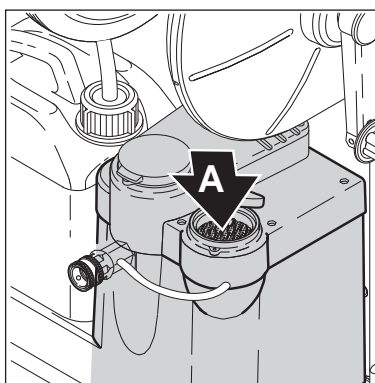

Store the cleaner in a dry heated location to protect against freezing or protect per below instructions:

1. Switch on the cleaner with the main switch in position 
2. Squeeze trigger of the

spray gun.

3. Turn off the water supply. Do not remove the water supply hose from the cleaner, this will result in water spraying everywhere.
4. Gradually pour antifreeze (approx. 5 litres) into the water tank (A).
5. The machine is protected against freezing when antifreeze mixture emerges from the spray gun.
6. Release the trigger of the spray gun.
7. Switch off the cleaner.
8. When the machine is put into service again, the antifreeze solution can be collected and stored for future use.

#### CAUTION

- Never startup a frozen cleaner. To avoid any possible damage, store the cleaner temporarily in a heated room before using it again.
- Frost damages are not covered by the guarantee.

# 7 Maintenance

## 7.1 Maintenance guidelines

To avoid hazards, damaged parts must be replaced either by your Nilfisk ALTO dealer, their customer service or a similarly qualified person.

Ensure that the machine is regularly serviced by authorised Nilfisk-ALTO dealers in accordance with the maintenance plan. Failure to do so will invalidate the warranty.

The cleaner must be disconnected from its power source during cleaning of the machine, maintenance, when replacing parts or converting the machine to another function.

## 7.2 Maintenance schedule

	Weekly	After the first 50 operating hours	Every six months or 500 operating hours	As required
Water filters				●
Oil filter				●
Checking the pump oil quality	●			
Changing the pump oil		●	●	
Emptying the fuel oil tank				●
Flame Sensor				●

## 7.3 Maintenance work

### 7.3.1 Water filters

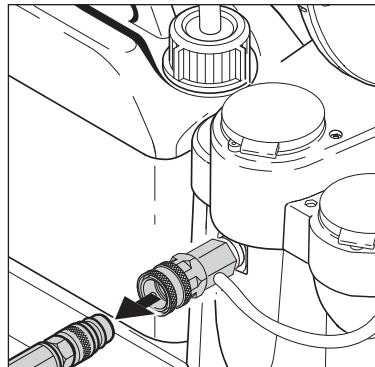

Water filters are fitted at the water and pump inlets to prevent large particles of dirt from entering into the system.

1. Unscrew quick coupling.
2. Remove filter with tool and clean it.

### 7.3.2 Maintenance of fuel filter

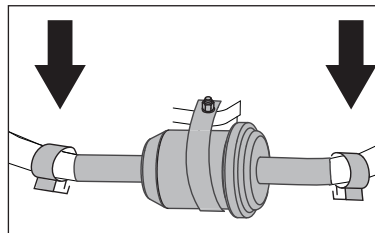

1. Open hose clips
2. Replace fuel filter
3. Close hose clips
4. Dispose the cleaning solution/damaged filter in accordance with the disposal regulations.

### 7.3.3 Checking the pump oil quality

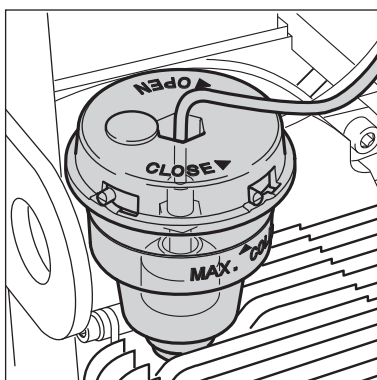

1. Check color of pump oil. If the oil has a grey or white shade, change the oil.
2. Top off oil level with fresh oil if necessary.

Oil type see chapter 9.4 Technical Data.

### 7.3.4 Changing the pump oil

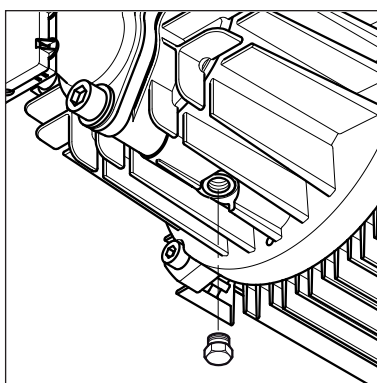

1. Unscrew the oil drain plug and drain oil into a suitable container.
2. Check that the drain plug gasket is in place and reinstall drain plug.
3. Fill pump with proper grade and amount of oil.

Oil grade and capacity see chapter '9.4 Technical Data'.

### 7.3.5 Emptying the fuel oil tank

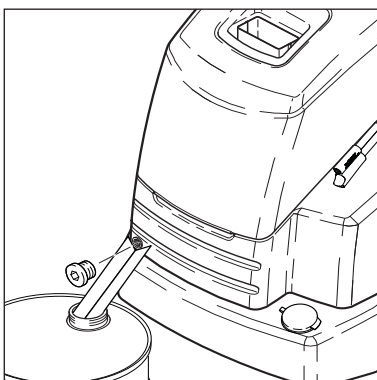

1. Prepare a container which is capable of containing the amount of fuel remaining in the tank.
2. Place drain channel beneath the drain plug.
3. Remove the drain plug and drain the fuel into the prepared container carefully not to spill fuel oil.
4. Check that the drain plug gasket is in place and reinstall drain plug.
5. Check tank and plug for leaks.



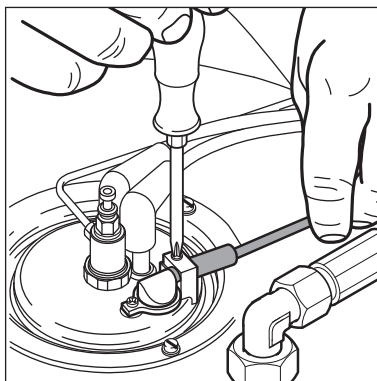







### 7.3.6 Flame sensor











1. Remove the sensor and clean with a soft cloth.
2. Confirm that the sensor is correctly seated when reinstalling.

# 8 Troubleshooting



## 8.1 Indications on Display

Indication on display	Cause	Remedy
<b>FLF</b>	> Flow sensor fault	 Contact Nilfisk-ALTO Service Cold water operation possible
<b>FLO</b>	> Water supply turned off or inadequate supply to machine > Detergent tank empty  > Pressure regulation on the safety control block set to low water volume > Machine scaled	<ul style="list-style-type: none"> <li>• Required volume flow and pressure see chapter 9.4 Technical Data</li> <li>• Fill detergent tank or set detergent metering to „OFF“</li> <li>• Turn the twist grip on safety control block to higher water pressure/volume</li> </ul>  Contact Nilfisk-ALTO Service
<b>FUE</b> 	> Fuel shortage	<ul style="list-style-type: none"> <li>• Fill fuel tank</li> <li>• Cold water operation possible</li> </ul>
<b>HOP</b>	> Motor overheated	<ul style="list-style-type: none"> <li>• Turn main switch in position „OFF“, let machine cool down</li> <li>• Remove extension cord, if being used.</li> <li>• Possible phase failure; have electrical connections checked</li> </ul>
<b>HOS</b>	> Machine overheated	 Contact Nilfisk-ALTO Service
<b>LEA</b>	> Leakage or inadmissible operating condition by short-time operation  > Spray gun leaking > High pressure hose, coupling or line system leaking > Detergent tank empty  > Water inlet filter dirty > High-pressure pump drawing in air	<ul style="list-style-type: none"> <li>• After three times of short-time operation the machine switches off. To reset: Turn main switch to position „OFF“, then start again. Keep trigger squeezed for longer than 3 seconds. If a leak occurs in the hose and gun and causes the machine to start and stop briefly 3 times, then the machine will switch off.</li> <li>• Repair Spray gun</li> <li>• Replace high-pressure hose, retighten screw fittings</li> <li>• Fill detergent tank or set detergent metering to „OFF“</li> <li>• Clean filter</li> <li>• Repair leaks</li> </ul>
<b>LHE</b>	> Flame sensor sooted > Ignition or fuel system failure	<ul style="list-style-type: none"> <li>• Clean flame sensor</li> </ul>  Contact Nilfisk-ALTO Service Cold water operation possible
<b>LHL</b>	> Burner failure	 Contact Nilfisk-ALTO Service Cold water operation possible
<b>POL</b> 	> Pump oil low	<ul style="list-style-type: none"> <li>• Fill to proper level</li> </ul>
<b>SEC</b>	> Temperature sensor damaged	 Contact Nilfisk-ALTO Service Cold water operation possible
<b>SEO</b>	> Temperature sensor damaged	 Contact Nilfisk-ALTO Service Cold water operation possible
<b>UPC</b>	> Microprocessor failure	 Contact Nilfisk-ALTO Service

## 8.2 Indication lights on control panel

Indication light	Cause	Remedy
 flashing	> see FLO	• see FLO
 ON	> Low fuel level	• Fill fuel tank Cold water operation possible
 ANTI STONE	> Low Nilfisk-ALTO AntiStone (Anti-Scale) level	• Fill Nilfisk-ALTO AntiStone (Anti-Scale) tank
 flashing	> Service interval: Service due in 20 hours	 Contact Nilfisk-ALTO Service
 ON	> Service interval expired	 Contact Nilfisk-ALTO Service
 ON	> Pump oil low	• Fill to proper level

## 8.3 Other Faults

Fault	Cause	Remedy
 not ON	> Power cord not properly connected to power supply	• Check power cord connection • Check fuse (see chapter 9.4 Technical Data)
Pressure too low	> High pressure nozzle worn out > Pressure regulation set to low pressure	• Replace nozzle • Turn the twist grip on safety control block clockwise (+)
Machine is running with pulsating pressure and makes knocking noise	> Pump has drawn in air due to detergent tank being empty	• Close detergent valve. Remove lance from gun. Operate spray gun and let machine run until air in pump is gone and the machine is running normally/calm again.
No detergents drawn in	> Detergent tank empty > Dirt in detergent tank > Suction valve at cleaning agent inlet soiled	• Fill detergent tank • Clean detergent tank • Remove suction valve and clean or replace
Burner soots	> Fuel contamination > Burner sooted or adjustment incorrect	 Contact Nilfisk-ALTO Service

## 9 Further information

### 9.1 Recycling the cleaner



Make the old cleaner unusable. Unplug the cleaner and cut the power cord.

Do not discard of electrical appliances with household waste.

As specified in European Directive 2002/96/EC on old electrical and electronic appliances, used electrical goods must be collected separately and recycled ecologically.

Contact your local authorities or your nearest dealer for further information.

### 9.2 Guarantee

Our general conditions of business are applicable with regard to the guarantee. Subject to change as a result of technical advances.

The guarantee is invalidated if the machine is not operated in accordance with these instructions or otherwise abused. The guarantee is invalidated if the machine is not serviced as described.

### 9.3 EU Declaration of Conformity



**Product**  
High Pressure Cleaner

**Type**  
NEPTUNE 7

**Description**  
200 / 3~ / 50Hz  
200 / 3~ / 60Hz  
220V / 1~ / 60Hz  
220/440V / 3~ / 60Hz  
400V / 3~ / 50Hz  
440/220 / 3~ / 60Hz

**The design of the unit corresponds to the following pertinent regulations**

EC Machine Directive 98/37/EG,  
EC Low-voltage Directive 73/23/EG,  
EC EMV Directive 89/336/EG





















**Applied harmonised standards**

EN 12100-1, EN 12100-2, EN 60335-2-79, EN 55014-1,  
EN 55014-2, EN 61000-3-2

A handwritten signature in black ink, appearing to read 'Anton Sørensen', written in a cursive style.

Anton Sørensen  
General Manager EAPC  
Technical Operations  
Brøndby, 2010-06

## 9.4 Technical data

Neptune 7 FA							
			7-58 / 7-58X	7-63	7-63	7-63	7-66
Voltage 200 / 3~ / 50Hz				(JP)			
Voltage 200 / 3~ / 60Hz				(JP)			
Voltage 220V / 1~ / 60Hz				(US)			
Voltage 220/440V / 3~ / 60Hz							(US)
Voltage 400V / 3~ / 50Hz						(EU)	
Voltage 440/220 / 3~ / 60Hz							(KR)
Fuse (slow)		A	30	30	16	16	30
Power rating		kW	6.6	8.3	8.3	9.3	9.1
Working pressure		bar/MPa	159/15.9	175/17.5	175/17.5	175/17.5	214/21.4
Permissible pressure		bar/MPa	250/25				
Volume flow max.		l/h	1200	1260	1260	1260	1200
Volume flow $Q_{IEC}$		l/h	1135	1170	1170	1170	1135
T max		°C	90	90	90	90	90
T max steam		°C	140	140	140	140	140
Permissible temperature		°C	90-140	90-140	90-140	90-140	90-140
Max. water inlet temperature		°C	40	40	40	40	40
Max. water inlet pressure		bar/MPa	10/1				
Dimensions l x w x h		mm	1190 x 702 x 1020	1190 x 702 x 1020	1190 x 702 x 1020	1190 x 702 x 1020	1190 x 702 x 1020
Weight		Kg	217 / 220(X)	217	217	224	217
Calculated sound pressure at a distance of 1 m EN 60704-1 $L_{pA} \pm K_{pA}^*$		dB(A)	76.6 ±/± 1,5	76.6 ±/± 1,5	76.6 ±/± 1,5	76.6 ±/± 1,5	76.6 ±/± 1,5
Sound power level $L_{WA} \text{ MAX}$ including $K_{WA} = 1,5\text{dB}^*$		dB(A)	91.7	91.7	91.7	91.7	91.7
Recoil forces		N	52	60	61	60	65
Fuel tank		l	35				
Detergent tank A/B		l	15/10				
Oil quantity		l	1.0				
Oil type			Castrol AlphaSyn-T ISO 150				

